

BELT CONVEYOR STRAIGHT, CURVE AND INCLINED

TECHNICAL HANDBOOK

Maintenance, Start Up and Troubleshooting for Your Omni Metalcraft Corp. Equipment



DO NOT OPERATE
BEFORE READING

Omni Metalcraft corp.

DO NOT DISCARD

TABLE OF CONTENTS

TABLE OF CONTENTS	2, 3
GENERAL SAFETY STATEMENTS	4
-Introduction	4
-Cautions, Warnings and Hazards	4
SAFETY INFORMATION	5
-Safety Labels.....	5, 6
-Installation Safety	7
-Electrical Safety	8
-Operational Safety	9
-Maintenance and Service Safety	10, 11
-Belt Safety Instructions	12
RECEIVING AND INSPECTION	13
-Returns, Damages and Shortages	13
-Removal of Crating	13
GENERAL INSTALLATION	14
-Understanding Pop-Out Rollers.....	14
-Belt Lacing	14
-Checking Unit Squareness.....	15
-Squaring	15
-Coupling / Attaching Bed Sections.....	16
LEG SUPPORTS AND INSTALLATION	17
-Permanent Installation of Legs.....	17-19
-Leg Adjustments	17-19
KNEE BRACES, CASTERS AND CEILING HANGERS	20
-Installing Knee Braces and Casters	20, 21
-Installing Ceiling Hangers	22
MULTI-TIER SUPPORTS	23
-Installation of Multi-Tier Supports.....	23
ASSEMBLY	24
-Straight Belt Conveyor Installation Instructions	24, 25
-Inclined Belt Conveyor Installation Instructions	26-28
INSTRUCTIONS FOR BELT TRACKING	29
-Belt Type 1	29
-Belt Type 2	30
-Belt Type 3	31
-Belt Type 4	32, 33
-Belt Type 5	34, 35
-Belt Curve Tensioning	36
PRE-START-UP OVERVIEW	37
-Preparing for Initial Start-Up	37
-Drive Chain and Sprocket Alignment	38
-Drive Chain and Sprocket Tension	39
-Gear Reducer Vent Plug	39

TABLE OF CONTENTS (Continued)

MAINTENANCE..... 40

-Inspection and Lubrication..... 40

-Maintenance Schedules 41

-Report on Miscellaneous Maintenance Performed 42

TROUBLESHOOTING AND REPLACEMENT PARTS..... 43

-Troubleshooting 43

PARTS LISTS..... 44

-Belt Straight Roller Bed 44

-Belt Straight Slider Bed 45

-Belt Curve..... 46

-Incline Belt Style 1 47

-Incline Belt Style 2 48

-Decline Belt Style 3 48

NOTES 49

WARRANTY 50

GENERAL SAFETY STATEMENTS

**IMPORTANT
REQUIRED READING!**



**¡IMPORTANTE!
¡LECTURA OBLIGATORIA!**







To ensure this quality product is safely and correctly utilized, all instructions within this manual must be read and understood prior to equipment start-up. Be aware of all safety labels on machinery. **If you do not understand any of the safety instructions or feel there may be safety labels missing, contact your supervisor or product supplier immediately!**

Para garantizar que este producto de calidad se utilice correctamente y con seguridad, es necesario leer y comprender las instrucciones incluidas en este manual, antes de comenzar a utilizar el equipo. Esté atento a todas las etiquetas de seguridad que se encuentran en las máquinas. Si no entiende alguna de las instrucciones de seguridad o considera que faltan algunas etiquetas de seguridad, ¡comuníquese inmediatamente con su supervisor o proveedor del producto!

COMPLIANCE WITH SAFETY STANDARDS

Compliance with safety standards, including federal, state and local codes or regulations is the responsibility of the conveyor purchaser(s). Placement of guards, safety labels and other safety equipment is dependent upon the area and use to which the system is applied. A safety study should be made of the conveyor application by the purchaser(s). It is the purchaser's responsibility to provide any additional guards, safety labels or other safety equipment deemed necessary based on this safety study.

The information contained in this safety manual is correct at the time of printing. Due to the continuing development of product lines, changes in specifications are inevitable. The company reserves the right to implement such changes without prior notice.

-  If you suspect fire hazards, safety hazards, dangers towards health or any other job safety concerns, consult your federal, state or local codes.
-  Certain safety information in this document was reprinted from ASME B20.1-2000 by permission of The American Society of Mechanical Engineers. All rights reserved.
Inspect equipment for **safety labels**. Make sure personnel are aware of and follow safety instructions.
-  Maintain an **orderly environment** in the vicinity of the conveyor at all times. Clean up spilled materials or lubricants immediately.
-  All personnel shall be instructed regarding the necessity for continuous care and attention to safety during the operation of a conveyor. They **must be trained** to identify and immediately report all unsafe conditions or practices relating to the conveyor and its operation.
-  Know your company's machine specific **Lockout / Tagout procedure**. **Do Not** perform maintenance until electrical disconnect has been turned off!
-  **Replace all safety devices, guards and guarding prior to equipment start-up.**

References used for safety instructions in this manual are from: Conveyor Equipment Manufacturers Association (CEMA) and The American Society of Mechanical Engineers (ASME)

SAFETY INFORMATION: SAFETY LABELS

Safety labels have been placed at various points on the equipment to alert everyone of potential dangers. Inspect equipment for proper position of safety labels and make sure all personnel are aware of the labels and obey their warnings. As mentioned in the previous section, a safety study should be made of the conveyor application by the purchaser(s). **It is the purchaser's responsibility to provide any additional guards, safety labels or other safety equipment deemed necessary based on this safety study.** The following pages contain typical safety labels that may have been attached to your equipment.

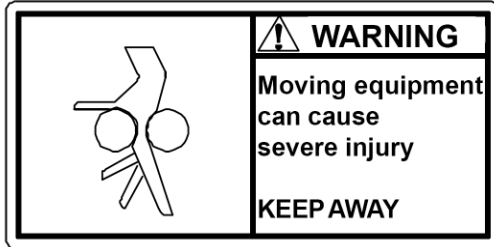

#110479 (5" x 2 1/2")
Placed on terminating ends (both ends) where there are exposed moving parts which must be unguarded to facilitate function, i.e. rollers, pulleys, shafts, chains, etc.

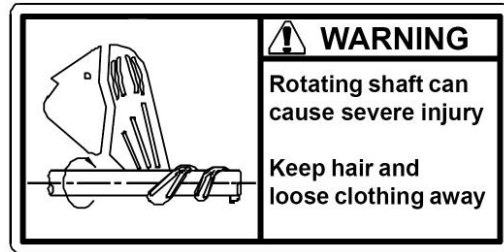

#113529 (5" X 2 1/2")
Placed next to drive (both sides) to warn personnel that the lineshaft conveyor utilizes a rotating shaft which may be hazardous if hair or loose clothing become entangled around the rotating shaft. Also used on any other conveyors where the exposed shaft may create similar hazards.

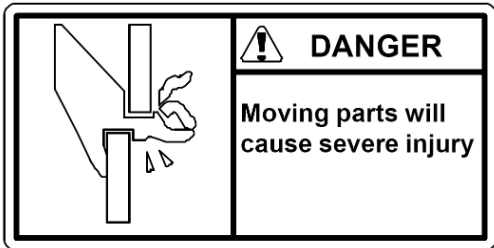

#111744 (5" X 2 1/2")
General warning to personnel that the equipment's moving parts, which operate unguarded by necessity or function, i.e., air cylinders, etc., create hazards to be avoided.



#110478 (5" X 2 1/2")
Placed on all chain guards to warn that operation of the machinery with guards removed would expose chains, belts, gears, shafts, pulleys, couplings, etc. which create hazards.



#111752 (5" X 2 1/2")
Placed on max. of 20' centers (both sides) along conveyors which provide surfaces and profiles attractive, but hazardous, for climbing, sitting, walking or riding.



#113513 (5" X 2 1/2")
Placed on chain guard base so label is visible when guard cover is removed.

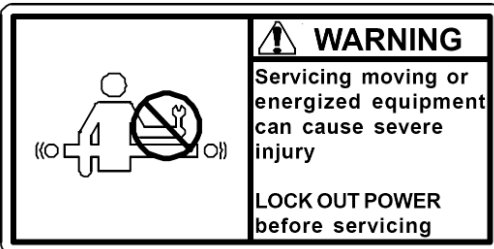

#113528 (5" X 2 1/2")
Placed next to drive (both sides) to warn maintenance personnel that conveyors must be shut off and locked out prior to servicing. Examples: drives, take-ups, and lubrication points, which require guard removal.



#111870 (5" X 3")
General warning of pinch point hazards.

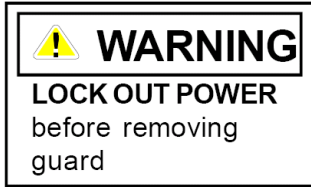

#111750 (1 3/4" x 1 1/4")
Generally placed on smaller guards to alert personnel of potential danger if guard is removed and power is not locked out.



#111749 (3" x 1 1/4")
Placed on shipping brace which stabilizes equipment during shipping. Brace must be removed before operating! May cause severe injury if not removed.



#110491 (10" x 7")
Placed on equipment where conveyors may start without warning.

SAFETY INFORMATION: INSTALLATION SAFETY

1) **LOADING / UNLOADING**

Have trained personnel load or unload equipment. The conveyor must be properly handled when transferring from the unloading area to final site location to prevent damage.

2) **GUARDS / GUARDING**

Interfacing of Equipment. When two or more pieces of equipment are interfaced, special attention shall be given to the interfaced area to ensure the presence of adequate guarding and safety devices.

Guarding Exceptions. Wherever conditions prevail that would require guarding under this standard but such guarding would render the conveyor unusable, seek guidance from your safety professional.



3) **ANCHORING**

DO NOT operate conveyor unless it is properly anchored. Serious injury or death may result.

4) **SAFETY WARNING**

Install all safety devices, guards and guarding prior to equipment start-up.

SAFETY INFORMATION: ELECTRICAL SAFETY

1) ELECTRICAL CODE

All electrical installations and wiring shall conform to federal, state and local codes.

When conveyor operation is not required for a maintenance procedure, **Electrical power must be turned off and locked / tagged out following your company's machine specific procedure.**



2) CONTROL STATION

Control stations should be so arranged and located that the operation of the affected equipment is visible from them. Control stations shall be clearly marked or labeled to indicate the function controlled.

A conveyor that would cause injury when started shall not be started until personnel in the area are alerted by a signal or by a designated person that the conveyor is about to start.

Where system function would be seriously hindered or adversely affected by the required time delay, or where the intent of the warning may be misinterpreted (i.e., a work area with many different conveyors and allied devices), a clear, concise and legible warning sign needs to be provided. The warning sign shall indicate that conveyors and allied equipment may be started at any time, that danger exists and that personnel must keep clear. These warning signs shall be provided along the conveyor at areas not guarded by position or location.

Remotely and automatically controlled conveyors, and conveyors where operator stations are not manned or are beyond voice or visual contact from drive areas, loading areas, transfer points and other potentially hazardous locations on the conveyor path not guarded by location, position or guards shall be furnished with emergency stop buttons, pull cords, limit switches or similar emergency stop devices.

All such emergency stop devices shall be easily identifiable in the immediate vicinity of such locations unless guarded by location, position or guards. Where the design, function and operation of such conveyor clearly is not hazardous to personnel, an emergency stop device is not required.

The emergency stop device shall act directly on the control of the conveyor concerned and shall not depend on the stopping of any other equipment. The emergency stop devices shall be installed so that they cannot be overridden from other locations.

Inactive and unused actuators, controllers and wiring should be removed from control stations and panel board, together with obsolete diagrams, indicators, control labels and other material that might confuse the operator.

3) SAFETY DEVICES

All safety devices, including wiring of electrical safety devices, shall be arranged to operate such that a power failure or failure of the device itself will not result in a hazardous condition.

4) EMERGENCY STOPS AND RESTARTS

Conveyor controls shall be so arranged that, in case of emergency stop, manual reset or start at the location where the emergency stop was initiated shall be required for the conveyor(s) and associated equipment to resume operation.

Before restarting a conveyor that has been stopped because of an emergency, an inspection of the conveyor shall be made and the cause of the stoppage determined. The starting device and electrical power must be turned off and locked / tagged out according to your company's machine specific procedure before any attempt is made to remove the cause of the stoppage, unless operation is necessary to determine the cause or to safely remove the stoppage.

5) SAFETY WARNING

Replace all safety devices, guards and guarding prior to equipment start-up.

SAFETY INFORMATION: OPERATIONAL SAFETY

Only trained, qualified personnel shall be permitted to operate a conveyor. Training shall include instruction in operation under normal conditions and emergency situations.

Where safety is dependent upon stopping / starting devices, they shall be kept free of obstructions to permit access.

The area around loading and unloading points shall be kept clear of obstructions that could endanger personnel.

Do not ride the load-carrying element of a conveyor under any circumstances, unless the conveyor is designed and equipped with safety and control devices intended to carry personnel. For no reason shall a person ride any element of a vertical conveyor. Warning labels reading **“DO NOT RIDE CONVEYOR”** shall be affixed by the owner of the conveyor.



Personnel working on or near a conveyor shall be instructed as to the location and operation of pertinent stopping devices.

A conveyor shall be used to transport only a load that it is designed to handle safely.

Under no circumstances shall the safety characteristics of the conveyor be altered.

Routine inspections and preventative and corrective maintenance programs shall be conducted to ensure that all safety features and guards are retained and function properly. Inspect equipment for safety labels. Make sure personnel are aware of and follow safety label instructions.

Alert all personnel to the potential hazard of entanglement in conveyors caused by items such as long hair, loose clothing and jewelry.

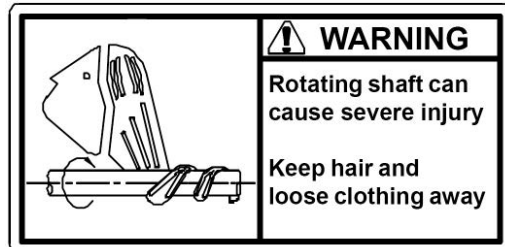

SAFETY WARNING

Replace all safety devices, guards and guarding prior to equipment start-up.

SAFETY INFORMATION: MAINTENANCE / SERVICE SAFETY

ELECTRICAL POWER MUST BE TURNED OFF AND LOCKED / TAGGED OUT following your company's machine specific procedures when servicing conveyor to prevent accidental restarting by other persons or interconnecting equipment (when used).

1) MAINTENANCE (REPAIR)

Maintenance and service shall be performed by trained, qualified personnel only.

Where lack of maintenance and service would cause a hazardous condition, the user shall establish a maintenance program to ensure that conveyor components are maintained in a condition that does not constitute a hazard to personnel.

No maintenance or service shall be performed when a conveyor is in operation. See "Lubrication" and "Adjustment or Maintenance During Operation" for exceptions.

When a conveyor is stopped for maintenance or service, the starting devices, prime mover, powered accessories or electrical must be locked / tagged out in accordance with a formalized procedure designed to protect all persons or groups involved with the conveyor against an unexpected restart. Personnel should be alerted to the hazard of stored energy, which may exist after the power source is locked out. All safety devices and guards shall be replaced before starting equipment for normal operation.

2) ADJUSTMENT OR MAINTENANCE DURING OPERATION

When adjustments or maintenance must be done while equipment is in operation, only trained, qualified personnel who are aware of the hazards of the conveyor in motion shall be allowed to make adjustments, perform maintenance or service.

Conveyors shall NOT be maintained or serviced while in operation unless proper maintenance or service requires the conveyor to be in motion. If conveyor operation is required, personnel shall be made aware of the hazards and how the task may be safely accomplished.

3) LUBRICATION

Conveyors shall **NOT** be lubricated while in operation unless it is impractical to shut them down for lubrication. Only trained and qualified personnel who are aware of the hazards of the conveyor in motion shall be allowed to lubricate a conveyor that is operating.

Where the drip of lubricants or process liquids on the floor constitutes a hazard, drip pans or other means of eliminating the hazard must be provided by purchaser(s).

4) MAINTENANCE OF GUARDS AND SAFETY DEVICES

Guards and safety devices shall be maintained in a serviceable and operational condition. Warning signs are the responsibility of the owner of the conveyor and must be maintained in a legible / operational condition.



5) INSPECTIONS

Routine inspections with preventative and /or corrective maintenance programs shall be conducted to ensure that all safety features and devices are maintained and function properly.

All personnel shall inspect for hazardous conditions at all times. Remove sharp edges or protruding objects. Repair or replace worn or damaged parts immediately.

6) CLEANING

Where light cleaning and/or casing cleaning are required, they shall be performed by trained personnel. The conveyor electrical power **must be turned off and locked / tagged out following your company's machine specific procedures**. Special attention may be required at feed and discharge points.

7) SAFETY WARNING

Replace all safety devices, guards and guarding prior to equipment start-up.

SAFETY INFORMATION: BELT CONVEYOR SAFETY INSTRUCTIONS

PARTICULAR DANGER AND PINCH POINTS

- 1) Any point at which a belt bends around a roller or pulley.
- 2) Any point where two rollers or pulleys (sheaves for spurs) are close together and produce a “wringer” effect.
- 3) Any point where accessories are located that also have moving parts.

RECEIVING AND INSPECTION: RETURNS, DAMAGES AND SHORTAGES

UNCRATING CHECKLIST

- 1) Compare the bill of lading with what you have received (including accessories).
- 2) Examine the equipment for damage.
- 3) Immediately report shortage or damages to the vendor and carrier.
- 4) Obtain a signed damage report from the carrier and send a copy to the vendor.

Do not attempt to modify or repair damaged equipment without authorization from vendor.

Note:

Do not return equipment to the factory without a written return authorization. Returns without written authorization will not be accepted.

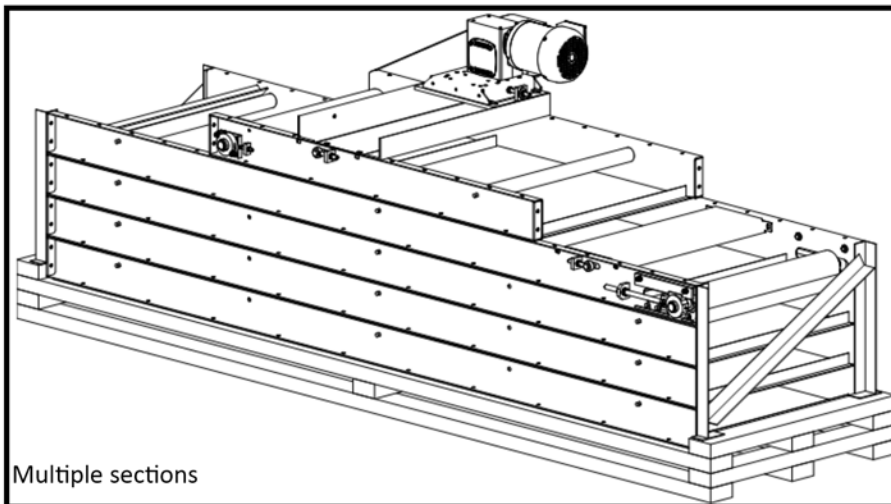
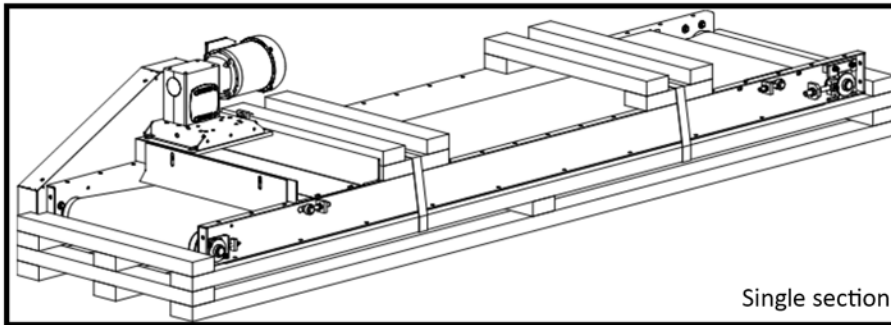

Note: Custom products may be crated differently to fit the conveyor design.

RECEIVING AND INSPECTION: REMOVAL OF CRATING

AFTER COMPLETING THE "UNCRATING CHECKLIST"

- 1) Remove crating and packaging.
- 2) Look for boxes, accessories, bags or components such as fasteners, manuals, guard rails etc. that may be banded or fastened to the crating material.

Note: Make sure all fasteners, guards and essential components are not discarded.

GENERAL INSTALLATION: BELT LACING AND TENSIONING

STRAIGHT BELT LACING

The conveyor belt has been cut to the proper length and lacing has been installed at the factory. To install, follow these steps:

- 1) Thread the belt through the conveyor as shown in on page 25 or 27 of this handbook.
- 2) Pull the ends together and insert the lacing pin as shown below.
- 3) Adjust the tension with the take-up pulley or tail pulley. Keep the pulley square by moving both tension bolts an equal amount. Maintain enough tension so that the drive pulley will not slip when carrying the rated load.
- 4) Track the belt per the instructions on page 29 - 36.

STRAIGHT BELT LACING

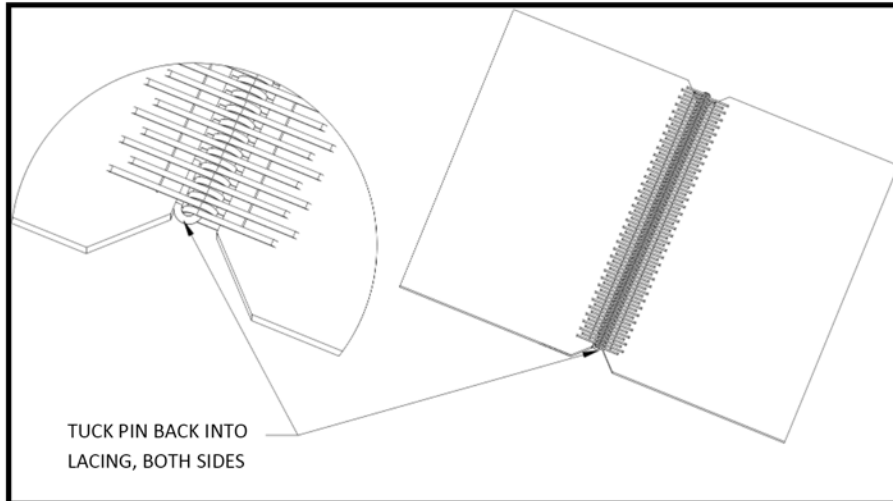

CURVE BELT LACING

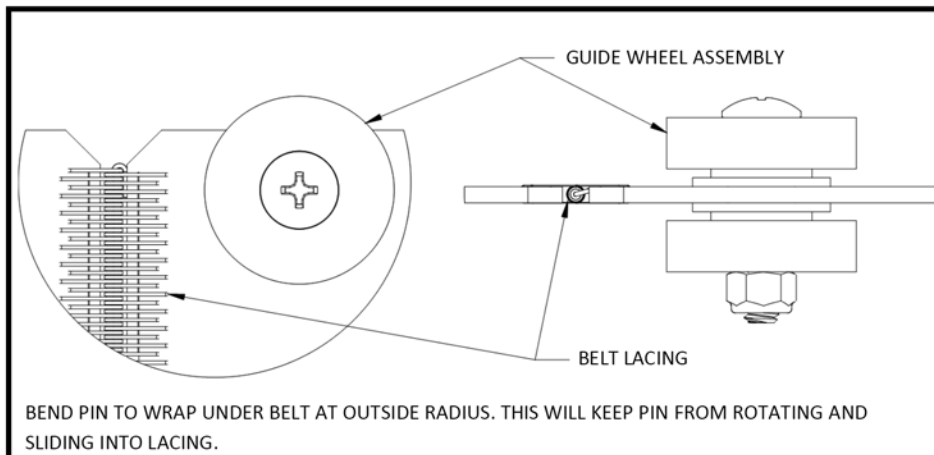

GENERAL INSTALLATION: CHECKING UNIT SQUARENESS

SQUARING

Frame squareness can be checked by using a simple right angle square as shown or by measuring from the same points diagonally, corner to corner.

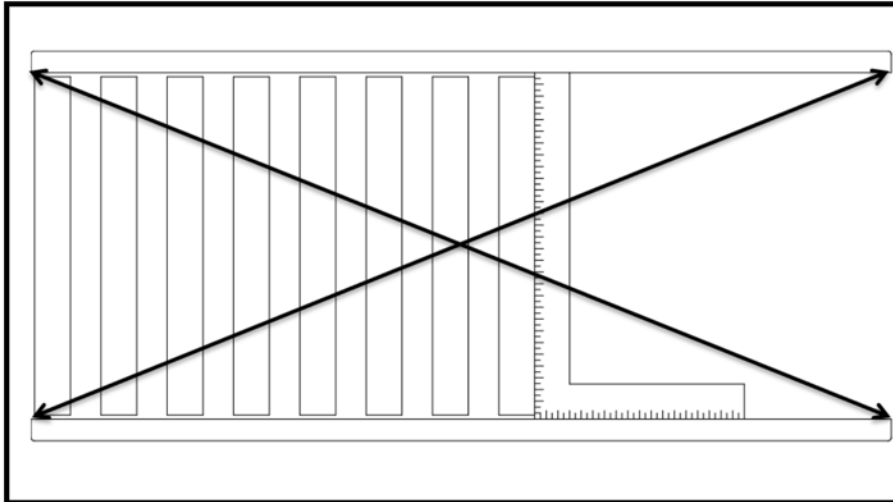

Note:

Make sure frames are square (as shown) or products will skew and tumble from the conveyor. Failure to square frames may also cause premature conveyor wear and failure.

GENERAL INSTALLATION: SQUARING

USING TURNBUCKLES TO SQUARE CONVEYOR

Bolt together conveyor frames may be brought square by means of attaching turnbuckles to each corner and turning them down appropriately until square.

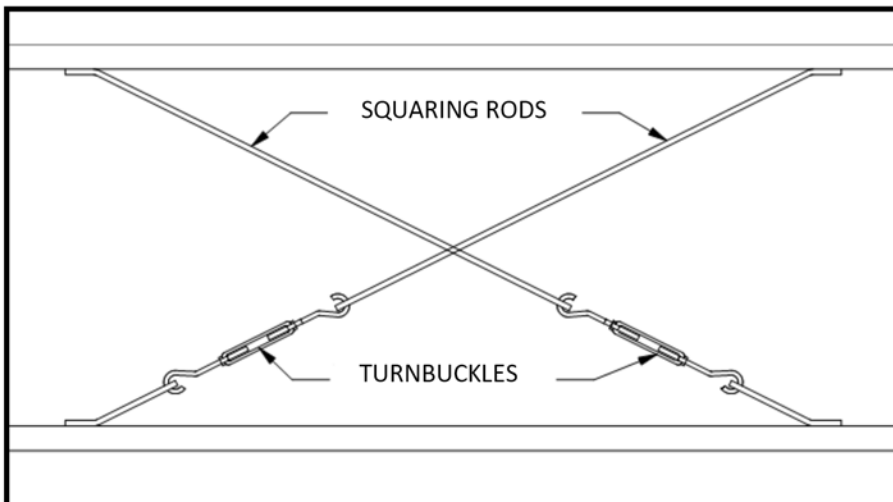

Note:

Only trained professionals should attempt to square up a conveyor. If frames have been damaged in freight, follow the "returns, damages and shortages" protocol on page 13.

GENERAL INSTALLATION: COUPLING / ATTACHING BED SECTIONS

COUPLING

Couple the sections using bolts provided per the drawing below.

ROLLER BED

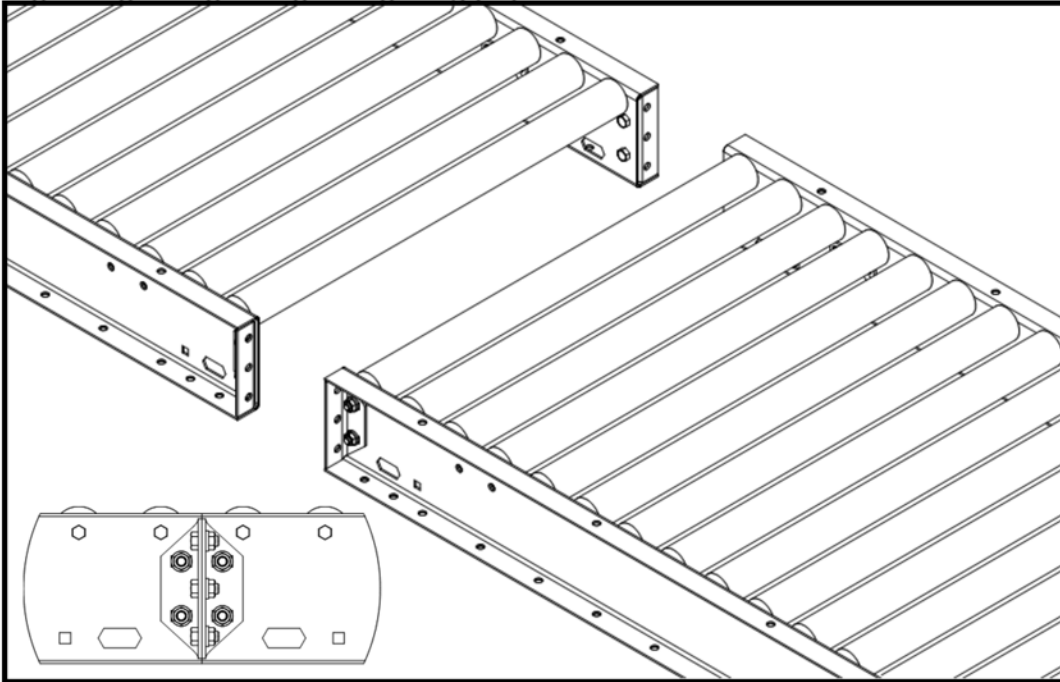

SLIDER BED

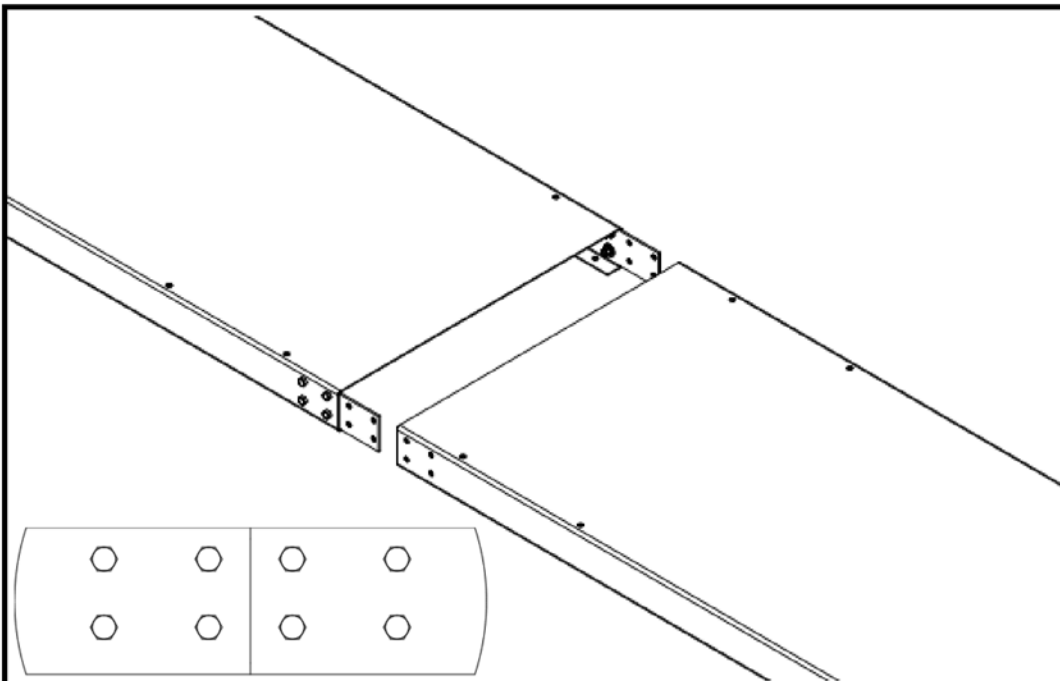

Note:

For ease of installation, mount legs on each conveyor section prior to coupling.

LEG SUPPORTS AND INSTALLATION: BOLT-TOGETHER

PERMANENT INSTALLATION OF LEGS

Secure leg supports to the floor utilizing the lag holes in the adjustable leg boot.

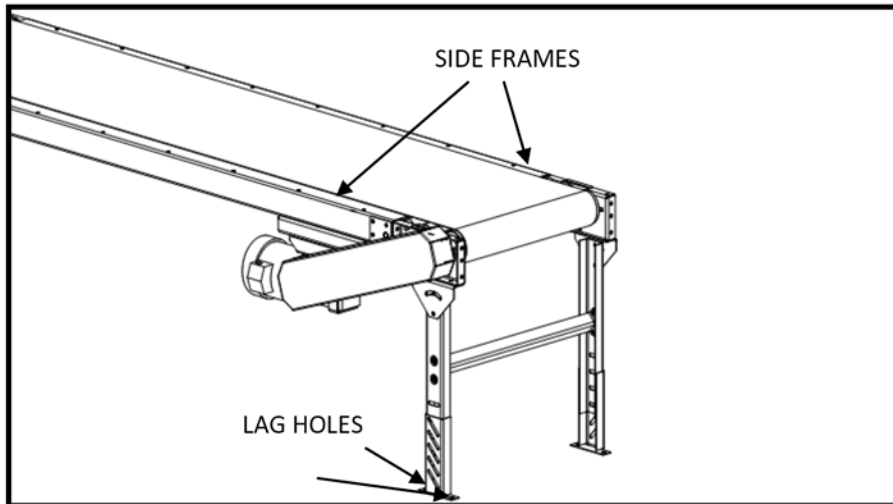

Note:

Make sure the conveyor is level by placing a level on the conveyor side frames. If the conveyor is not level, adjust the legs appropriately as shown below.

LEG ADJUSTMENT: BOLT-TOGETHER LEGS

- 1) The conveyor electrical power must be turned off and locked / tagged out following your company's machine specific procedures.
- 2) Remove all load from the conveyor.
- 3) Position conveyor in the location to be installed.
- 4) Support conveyor section with jack, hoist or forklift.
- 5) Carefully loosen the fasteners within the slots.
- 6) Lift or lower conveyor until it is at the desired height.
- 7) Ensure that the conveyor is completely level. (reference leveling note below)
- 8) Tighten fasteners using torque appropriate for each fastener's size and grade. (grade 5 fasteners provided)

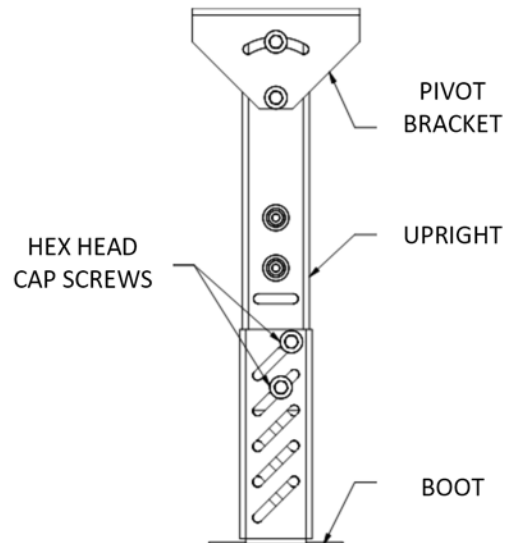

Note:

Only qualified installation professionals should level and install conveyor.

LEG SUPPORTS AND INSTALLATION: WELDED

PERMANENT INSTALLATION OF LEGS

Secure leg supports to the floor utilizing the lag holes in the adjustable leg boot.

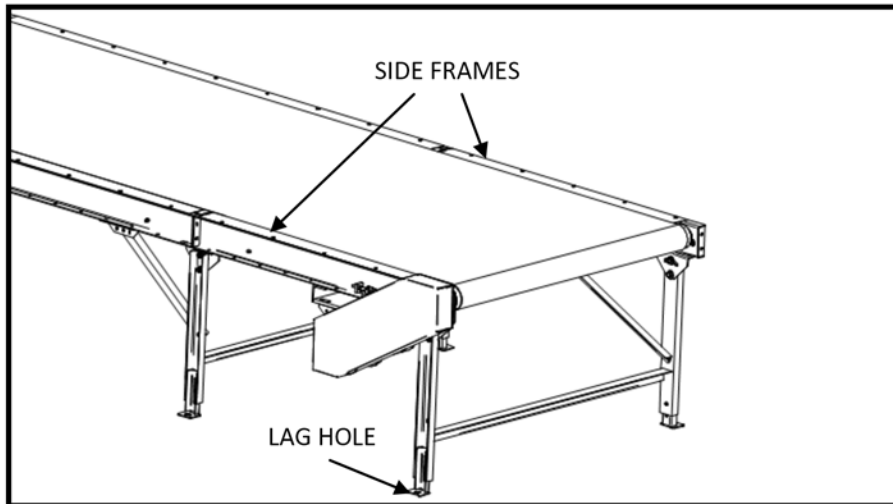

Note:

Make sure the conveyor is level by placing a level on the conveyor side frames. If the conveyor is not level, adjust the legs appropriately as shown on page 19.

LEG SUPPORTS AND INSTALLATION: WELDED

WELDED LEG ADJUSTMENTS

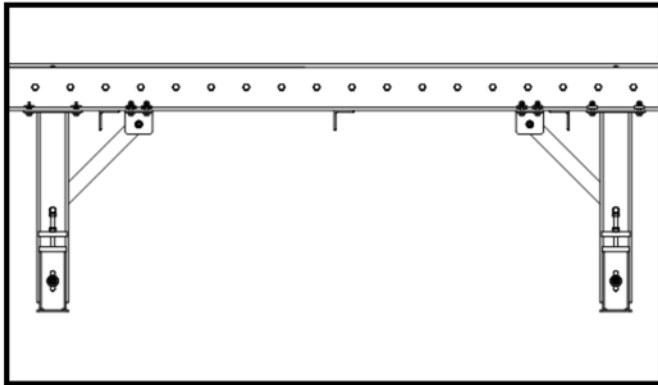

Note:

Only qualified installation professionals should level and install conveyor.

WELDED LEG ADJUSTMENT: JACK-BOLT

- 1) The conveyor electrical power must be turned off and locked / tagged out following your company's machine specific procedures.
- 2) Remove all load from the conveyor .
- 3) Position conveyor in the location to be installed.
- 4) Support conveyor section with jack, hoist or forklift.
- 5) Carefully loosen the retaining bolt.
- 6) Carefully loosen the jam nut holding the jack-bolt in position on the jack-bolt plate.
- 7) Adjust the boot position by turning the jack-bolt.
- 8) Ensure that the conveyor is completely level. (reference leveling note above)
- 9) Tighten the jam nut securely against the jack-bolt plate using torque appropriate for each fastener's size and grade. (grade 5 fasteners provided)
- 10) Tighten the retaining bolt using torque appropriate for each fastener's size and grade. (grade 5 fasteners provided)

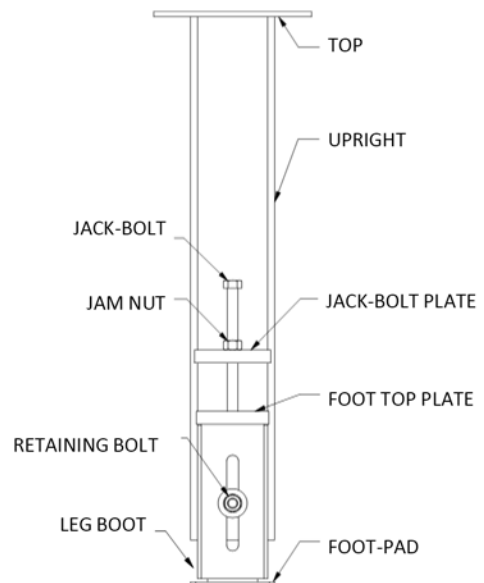

WELDED LEG ADJUSTMENT: NON-JACK-BOLT

- 1) The conveyor electrical power must be turned off and locked / tagged out following your company's machine specific procedures.
- 2) Remove all load from the conveyor .
- 3) Position conveyor in the location to be installed.
- 4) Support conveyor section with jack, hoist or forklift.
- 5) Carefully loosen the retaining bolt.
- 6) Lift or lower conveyor until it is at the desired height.
- 7) Ensure that the conveyor is completely level. (reference leveling note above)
- 8) Tighten fasteners using torque appropriate for each fastener's size and grade. (grade 5 fasteners provided)
- 9) Secure the leg boot to the upright by either of the methods listed below:
 - A) Weld the boot into place.
 - B) Drill through boot and upright and bolt the boot securely into place.

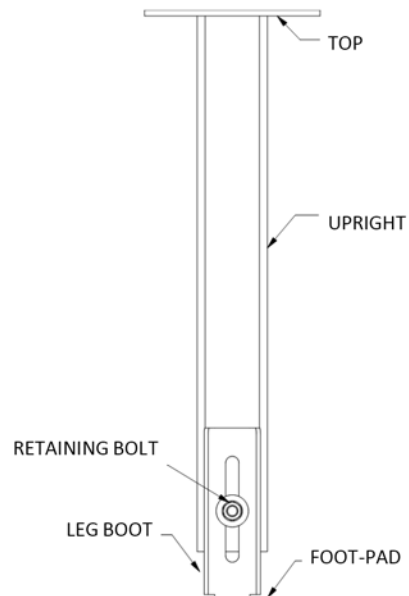

KNEE BRACES, CASTERS AND CEILING HANGERS: INSTALLING KNEE BRACES

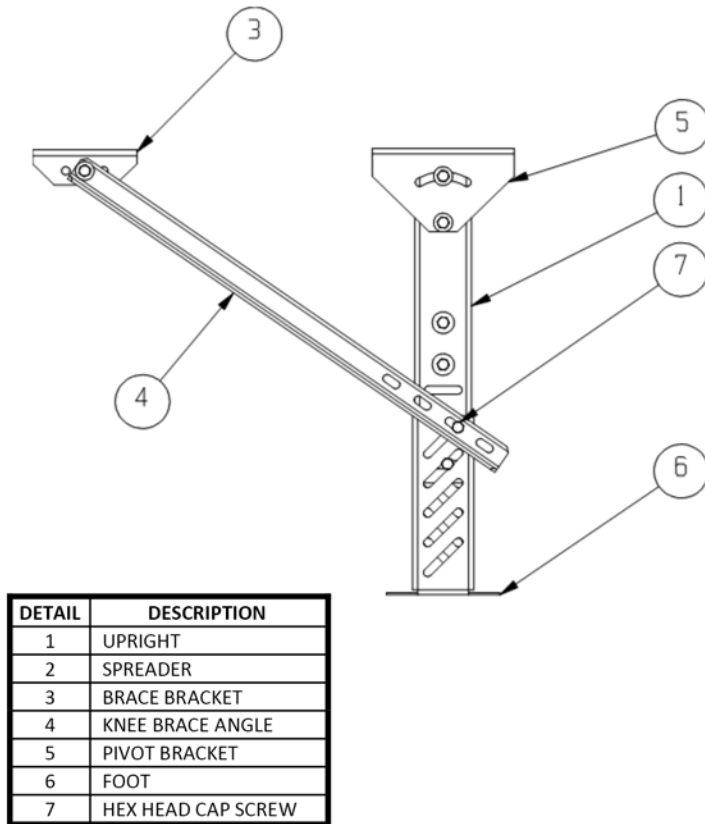

DETAIL	DESCRIPTION
1	UPRIGHT
2	SPREADER
3	BRACE BRACKET
4	KNEE BRACE ANGLE
5	PIVOT BRACKET
6	FOOT
7	HEX HEAD CAP SCREW

INSTALLING KNEE BRACES

- 1) After leg supports are set in place, attach the brace bracket.
- 2) Attach knee brace angle to the leg support and brace bracket.

(knee brace angle may need to be cut, drilled and trimmed for proper fit and to eliminate interference with adjacent equipment)

Note:

Knee braces are recommended when the conveyor height exceeds 36" and/or when additional stability is needed.

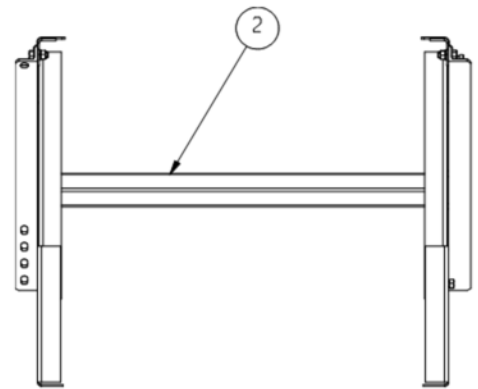

KNEE BRACES, CASTERS AND CEILING HANGERS: INSTALLING CASTERS

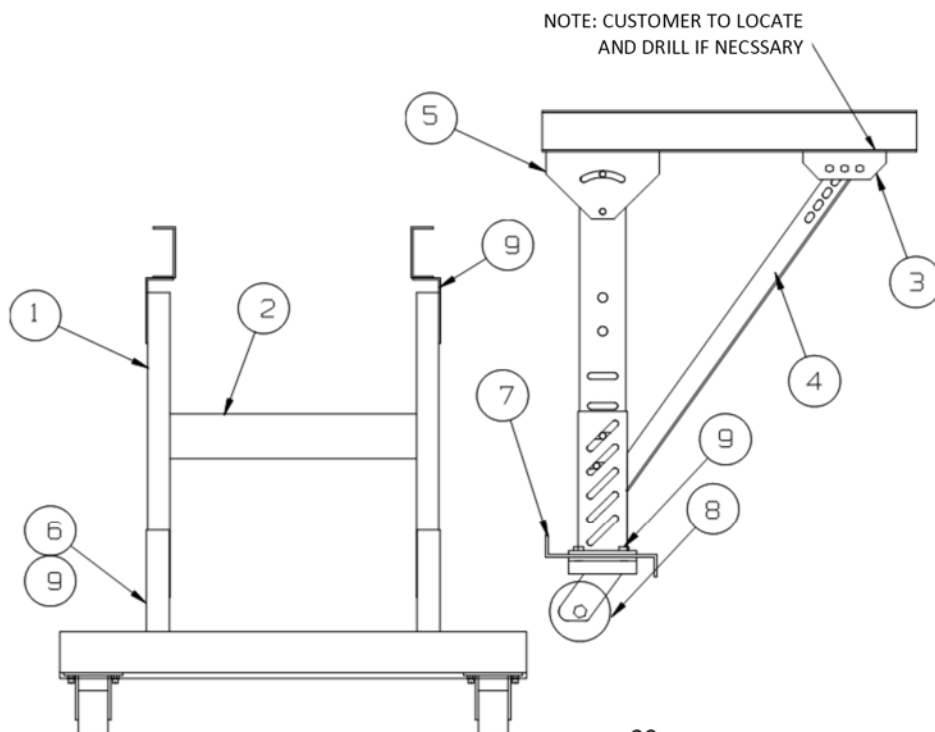

INSTALLING CASTERS

Once in position, casters should be locked until conveyor needs to be moved again.

Note:

Leg supports with casters follow similar installation instructions as standard leg supports and knee braces.

DETAIL	DESCRIPTION
1	UPRIGHT
2	SPREADER
3	BRACE BRACKET
4	KNEE BRACE ANGLE
5	PIVOT BRACKET
6	FOOT
7	Z-PLATE
8	PHENOLIC CASTER
9	HEX HEAD CAP SCREW

KNEE BRACES, CASTERS AND CEILING HANGERS: INSTALLING WELDED KNEE BRACES

INSTALLING KNEE BRACES

- 1) After leg supports are set in place, attach the brace bracket.
- 2) Attach knee brace angle to the leg support and brace bracket.

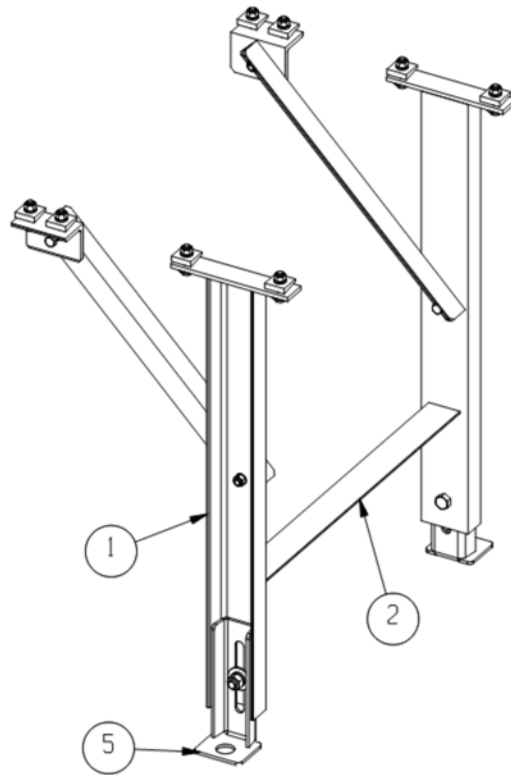
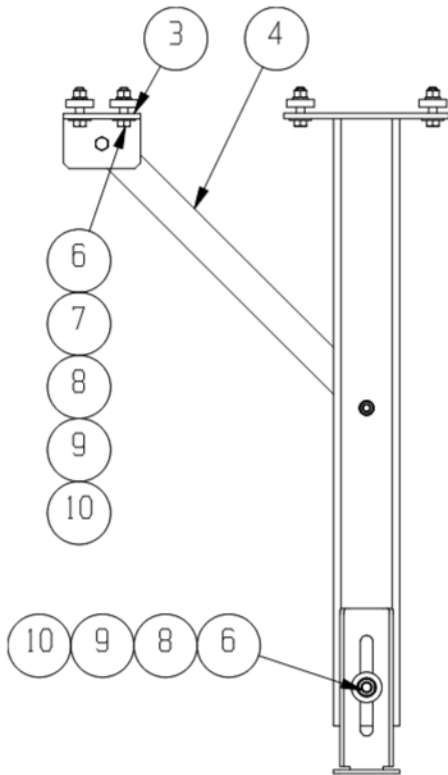

DETAIL	DESCRIPTION
1	UPRIGHT
2	SPREADER
3	BRACE BRACKET
4	KNEEBRACE ANGLE
5	FOOT
6	HEX HEAD CAP SCREW
7	BEVEL WASHER
8	HEX NUT
9	FLAT WASHER
10	LOCK WASHER

Note:

Knee braces are recommended when the conveyor height exceeds 36" and/or when additional stability is needed.

KNEE BRACES, CASTERS AND CEILING HANGERS: INSTALLING CEILING HANGERS

INSTALLING CEILING HANGERS

When using conveyors in an overhead scenario, mount hangers at section joints.

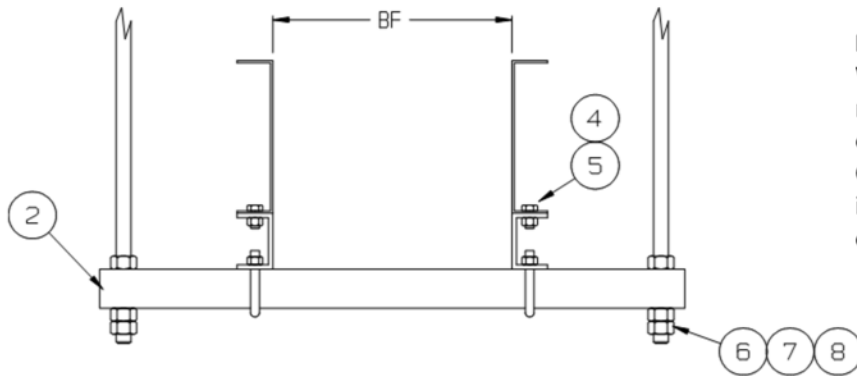

Note:

When installing ceiling hangers, refer to local building codes to ensure that materials comply. Only experienced material handling installers should attempt to install conveyors.

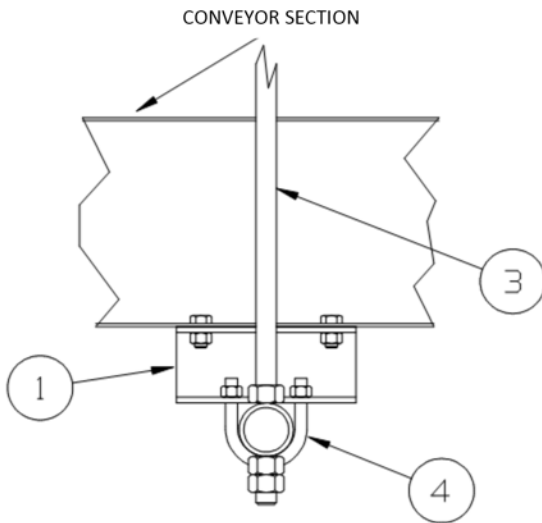

DETAIL	DESCRIPTION
1	HANGER CHANNEL
2	PIPE SPREADER
3	THREADED ROD
4	U-BOLT
5	WHIZ NUT
6	HEX HEAD CAP SCREW
7	HEX NUT
8	LOCK WASHER

MULTI-TIER SUPPORTS: INSTALLATION OF MULTI-TIER SUPPORTS

INSTALLING MULTI-TIER SUPPORTS

- 1) Remove the upper spreader weldments (detail 3) from support.
- 2) Lower the conveyor section onto the lower spreader weldments (detail 3).
- 3) Check for appropriate elevation and attach the knee bracket assembly (detail 5,6,7,8)
- 4) For upper conveyor assembly, repeat steps 2 and 3.
- 5) Make sure all multi-tier supports are in line and square prior to conveyor start-up.

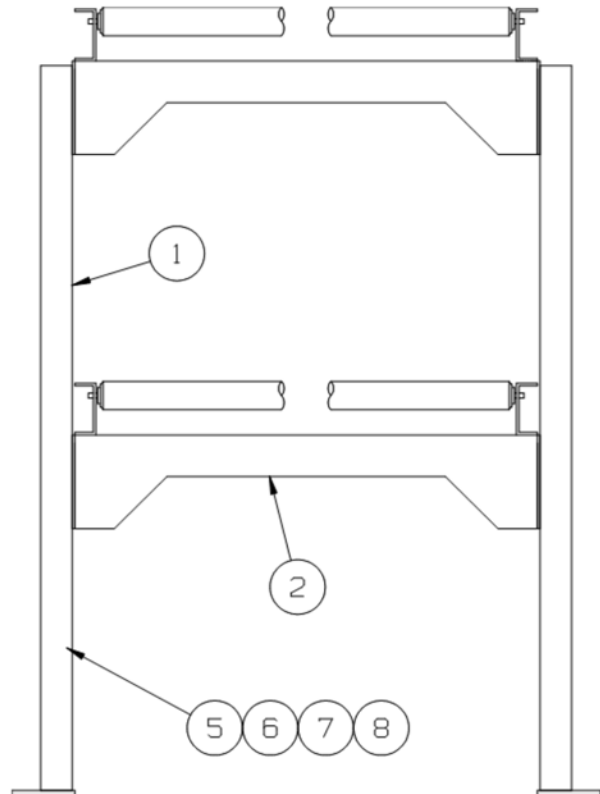
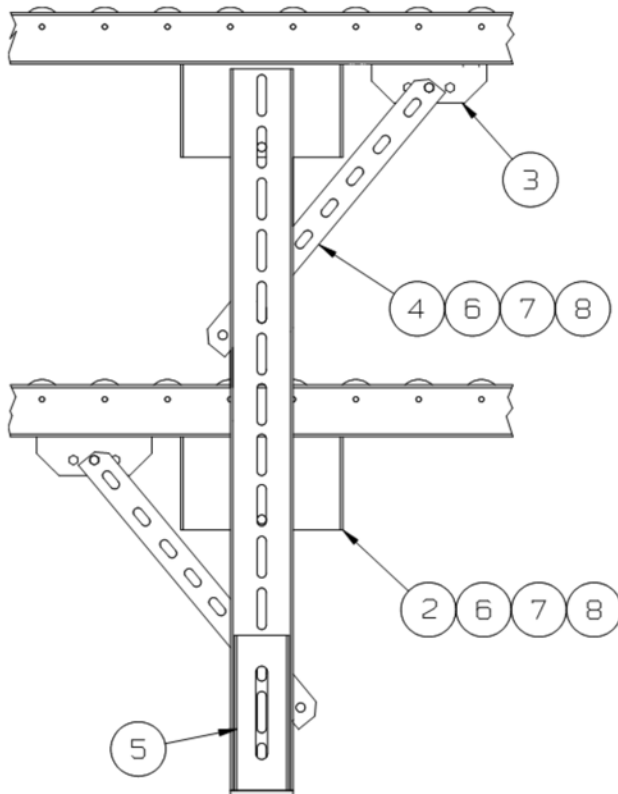

Note: Make sure that the conveyor is stable prior to multi-tier assembly. Use of a forklift or crane may be required to ensure safe handling. Only experienced installation professionals should install conveyor.

DETAIL	DESCRIPTION
1	UPRIGHT
2	SPREADER
3	BRACE BRACKET
4	KNEE BRACE ANGLE
5	FOOT WELDMENT
6	WHIZ NUT
7	HEX HEAD CAP SCREW
8	FLAT WASHER

GENERAL INSTALLATION: STRAIGHT BELT CONVEYOR INSTALLATION INSTRUCTIONS

SLIDER AND ROLLER BED BELT CONVEYOR INSTALLATION INSTRUCTIONS

- 1) Fasten floor supports or ceiling supports (page 17 or 22) to bottom of drive section assembly and fasten supports to take-up section assembly.
- 2) Attach supports to intermediate sections. Secure supports to approximate height.
- 3) Assemble intermediate sections one at a time to drive section assembly, using splice plate couplers (slider bed) or supplied end couplers (roller bed). When all intermediate sections are assembled, attach take-up section assembly as shown. Adjust supports to exact height required.

END DRIVE

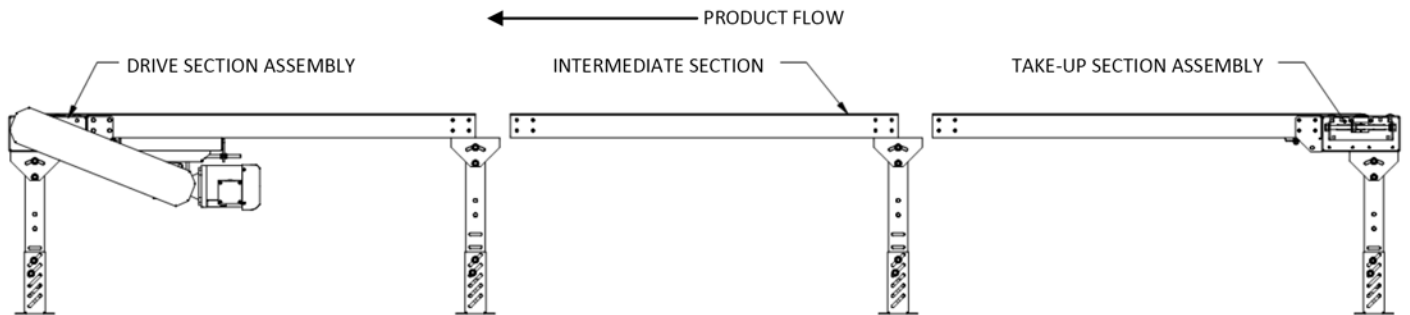

CENTER DRIVE

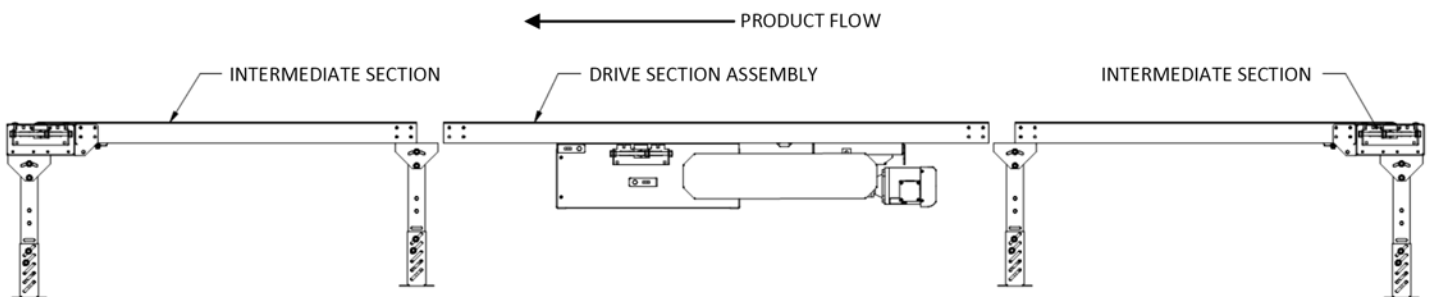

GENERAL INSTALLATION: STRAIGHT BELT CONVEYOR INSTALLATION INSTRUCTIONS

- 4) Loop belt over snub rollers, return rollers and end pulleys as shown below. Bring laced ends together and thread steel pin through loops.

END DRIVE

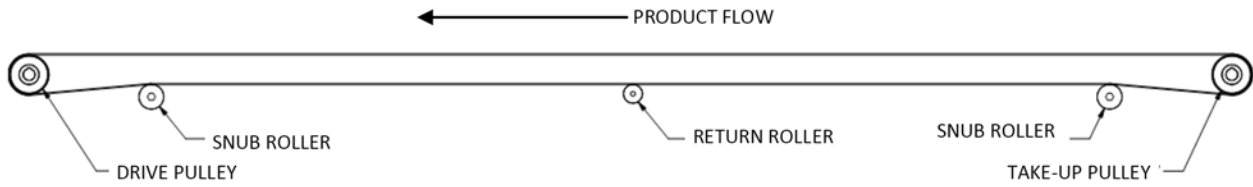

CENTER DRIVE

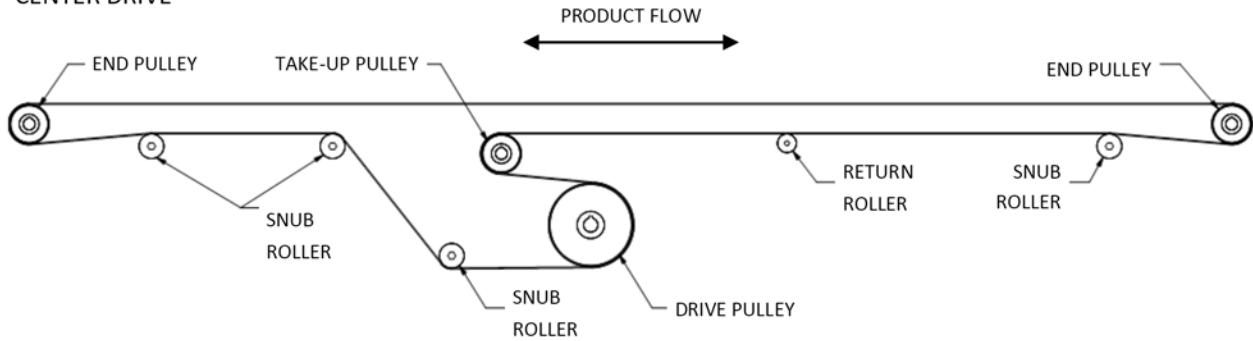

- 5) Remove excess slack from belt by adjusting the take-up pulley. Do not over tighten belt because it will be difficult, if not impossible, to track the belt.
 Note: When adjusting the take-up pulley, the idler rollers may be in the way. Remove them and install them on the opposite side of the take-up pulley. You will have zero to two idler rollers outboard of the take-up pulley dependent upon the travel required.
- 6) Check all frame sections, end units, drive units, etc. for squareness (page 15). All snub rollers and pulleys must be set square with the frame before making any belt adjustments.
- 7) See belt tracking instructions for Type 1 (End Drive) on page 29 or Type 2 (Center Drive) on page 30.

GENERAL INSTALLATION: INCLINED BELT CONVEYOR INSTALLATION INSTRUCTIONS

INCLINED SLIDER AND ROLLER BED BELT CONVEYOR INSTALLATION INSTRUCTIONS

- 1) Fasten floor supports or ceiling supports (page 17 or 22) to bottom of drive section assembly and fasten supports to take-up section assembly.
- 2) Attach supports to intermediate sections. Secure supports to approximate height.
- 3) Assemble intermediate sections one at a time, to drive section assembly, using splice plate couplers (slider bed) or supplied end couplers (roller bed). When all intermediate sections are assembled, attach take-up section assembly as shown. Adjust supports to exact height required.

END DRIVE

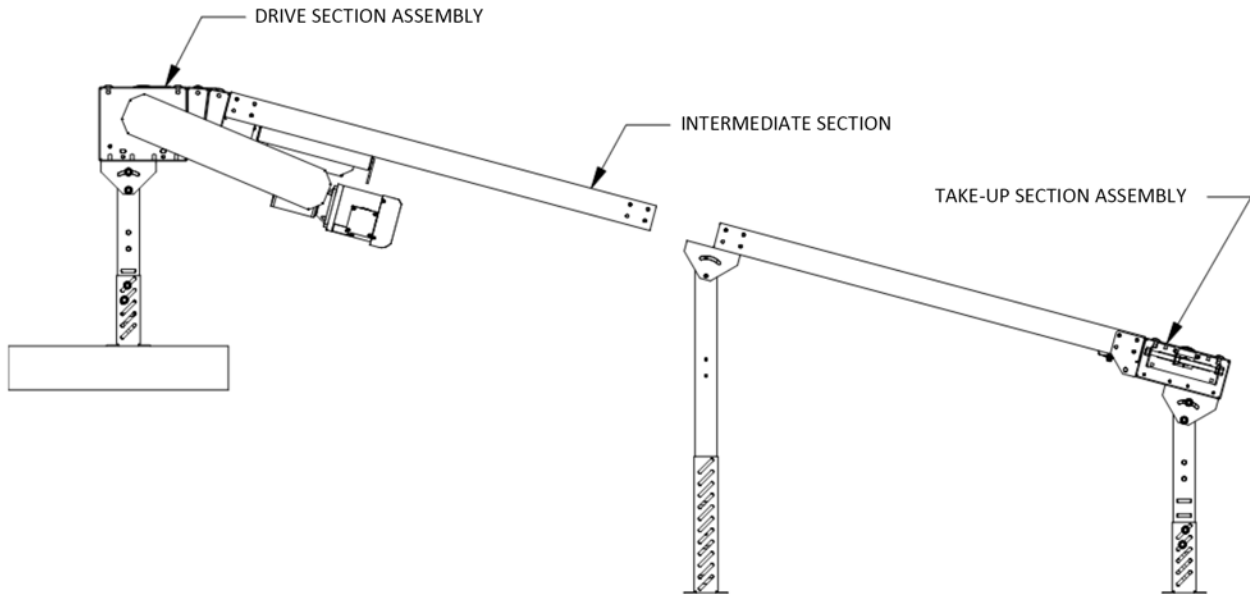

CENTER DRIVE

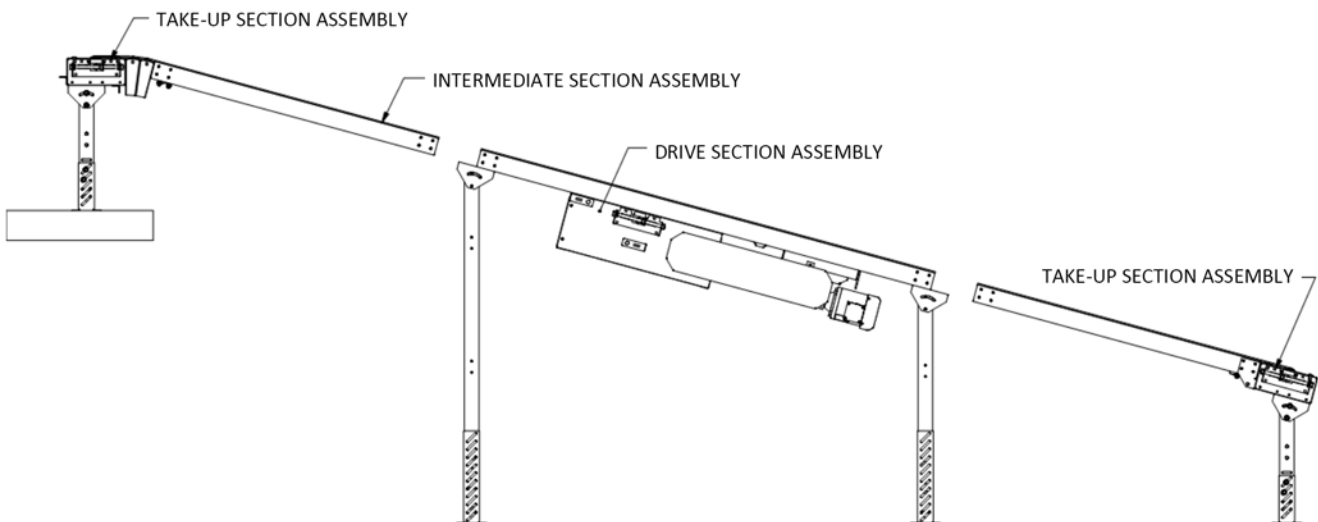

GENERAL INSTALLATION: INCLINED BELT CONVEYOR INSTALLATION INSTRUCTIONS

- 4) Loop belt over snub rollers, return rollers and end pulleys as shown below. Bring laced ends together and thread steel pin through loops.

END DRIVE

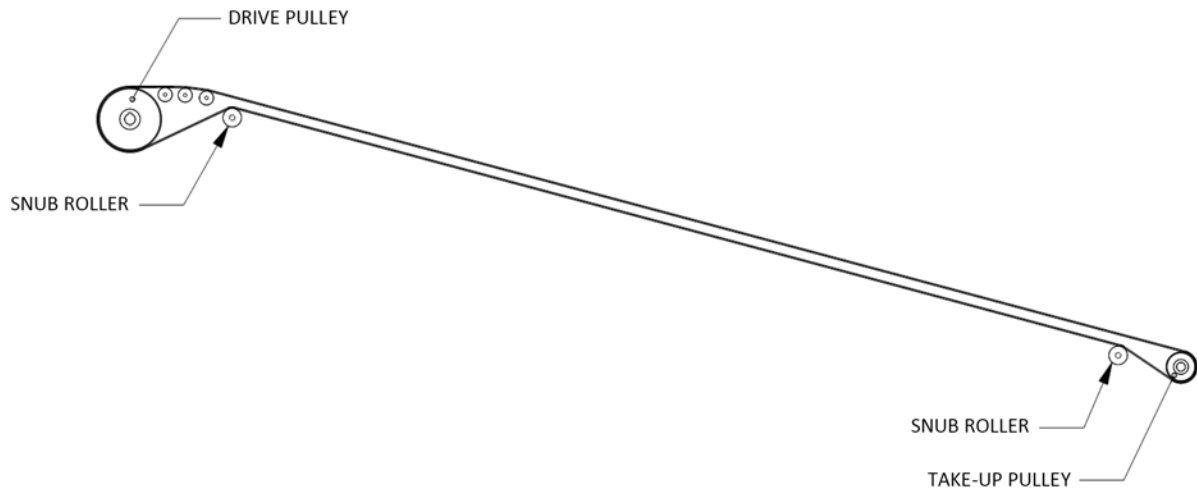

CENTER DRIVE

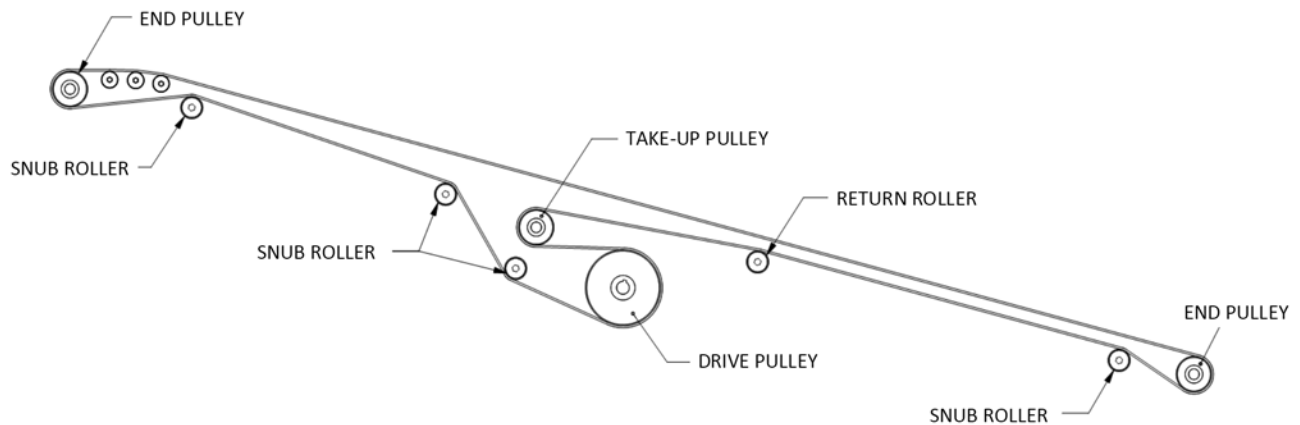

- 5) Remove excess slack from belt by adjusting the take-up pulley. Do not over tighten belt because it will be difficult, if not impossible, to track the belt.
 Note: When adjusting the take-up pulley, the idler rollers may be in the way. Remove them and install them on the opposite side of the take-up pulley. You will have zero to two idler rollers outboard of the take-up pulley dependent upon the travel required.
- 6) Check all frame sections, end units, drive units, etc. for squareness (page 15). All snub rollers and pulleys must be set square with the frame before making any belt adjustments.
- 7) See belt tracking instructions for Type 3 (End Drive) on page 31 or Type 4 (Center Drive) on page 32.

GENERAL INSTALLATION: INCLINED BELT CONVEYOR INSTALLATION INSTRUCTIONS

INCLINED SLIDER AND ROLLER BED POWER INFEED BELT CONVEYOR INSTALLATION INSTRUCTIONS

- 1) Fasten floor supports or ceiling supports (page 17 or 22) to bottom of power take-off section assembly and fasten supports to take-up section assembly. Set at approximate angle required.
- 2) Attach supports to last intermediate section of incline conveyor. Attach end of intermediate section assembly to power take-off section assembly, using end couplers and gussets.

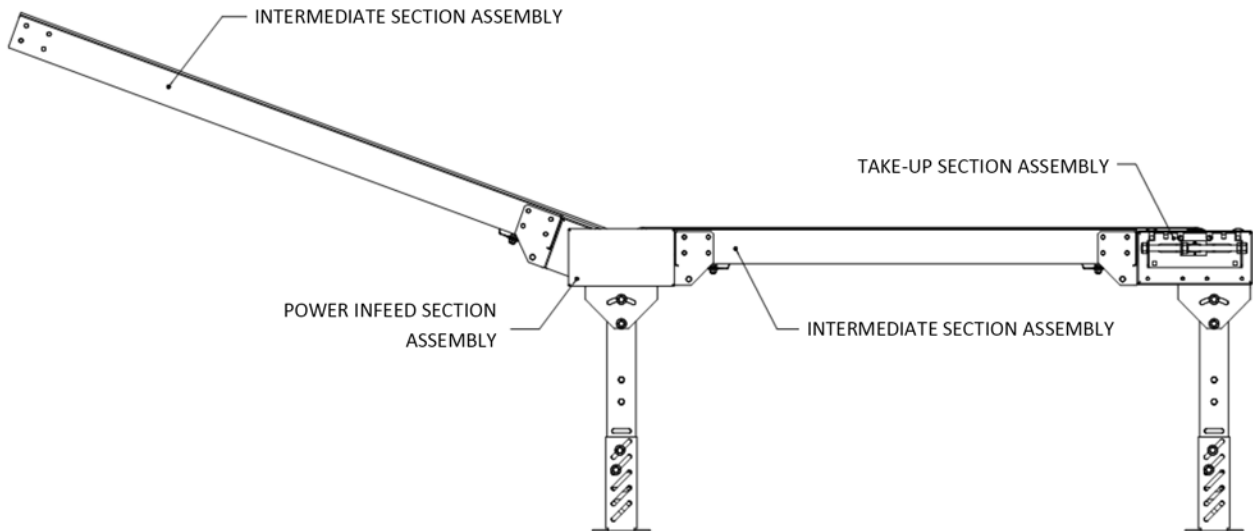

- 3) Loop belt over snub rollers, return rollers and end pulleys as shown below. Bring laced ends together and thread steel pin through loops.

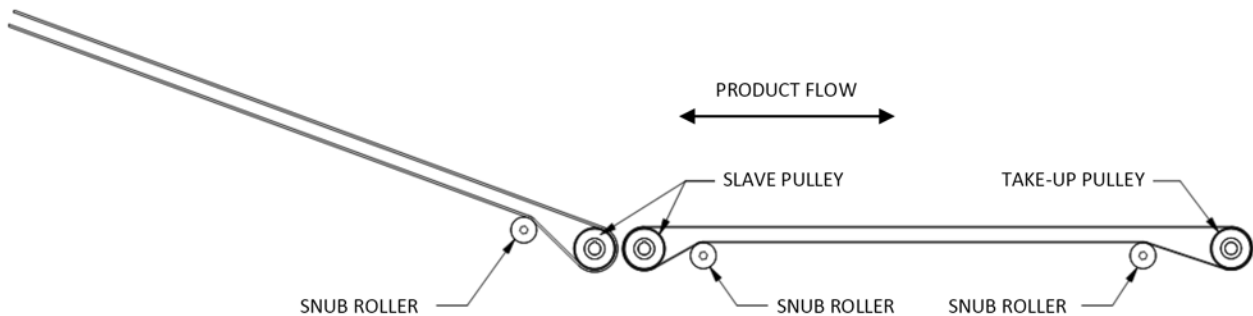

- 4) Remove excess slack from belt by adjusting the take-up pulley. Do not over tighten belt because it will be difficult, if not impossible, to track the belt.
 Note: When adjusting the take-up pulley, the idler rollers may be in the way. Remove them and install them on the opposite side of the take-up pulley. You will have zero to two idler rollers outboard of the take-up pulley dependent upon the travel required.
- 5) Check all frame sections, end units, drive units, etc. for squareness (page 15). All snub rollers and pulleys must be set square with the frame before making any belt adjustments.
- 6) See belt tracking instructions for Type 5 on page 34.

INSTRUCTIONS FOR BELT TRACKING: BELT TYPE 1

Note: All snub rollers and pulleys **must be** set square with the frame before making any belt tracking adjustments. Mark initial belt position before beginning. Make all adjustments in small increments. **CONVEYOR POWER MUST BE TURNED OFF WHEN MAKING ANY ADJUSTMENTS.** Do not overtighten the belt. Belt should be just tight enough to pull product load.

BELT TYPE 1: ONE-WAY SERVICE, LEVEL OR SLIGHTLY INCLINED WITH END DRIVE

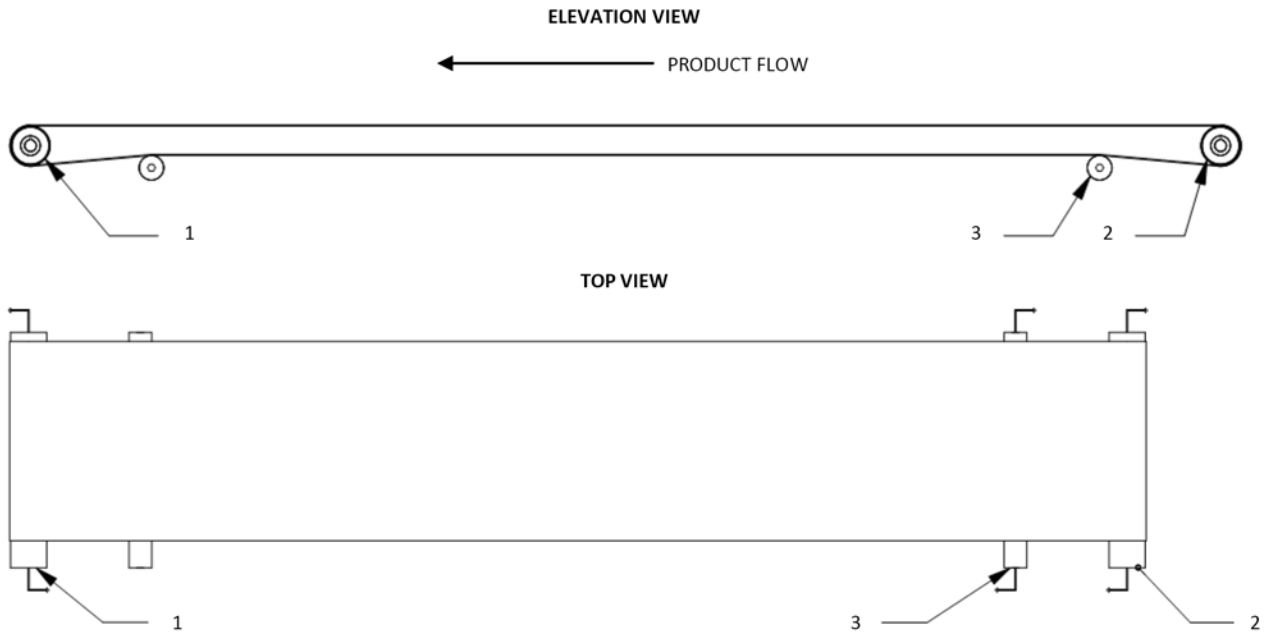

Note: If belt is running off-center to opposite than shown, adjust rollers and pulleys in opposite direction than shown.

- 1) Run conveyor for a few minutes so the belt can take its position. **Stop conveyor immediately if belt rubs against side of conveyor.** If belt shifts to one side, adjust snub roller (3) to steer belt to center of take-up pulley (2).
- 2) If belt is riding at the center of the take-up pulley (2) but not at the center of the drive pulley (1), adjust drive pulley (1) slightly as shown. The belt will travel toward the slack side.
- 3) Adjusting the drive pulley (1) may throw off belt alignment on the take-up pulley (2). Repeat steps 1 and 2 as necessary. The belt will stretch during the first few days of operation. Adjust the take-up pulley (2) to compensate for the stretch.

INSTRUCTIONS FOR BELT TRACKING: BELT TYPE 2

Note: All snub rollers and pulleys **must be** set square with the frame before making any belt tracking adjustments. Mark initial belt position before beginning. Make all adjustments in small increments. **CONVEYOR POWER MUST BE TURNED OFF WHEN MAKING ANY ADJUSTMENTS.** Do not overtighten the belt. Belt should be just tight enough to pull product load.

BELT TYPE 2: TWO-WAY SERVICE, LEVEL OR SLIGHTLY INCLINED WITH CENTER DRIVE

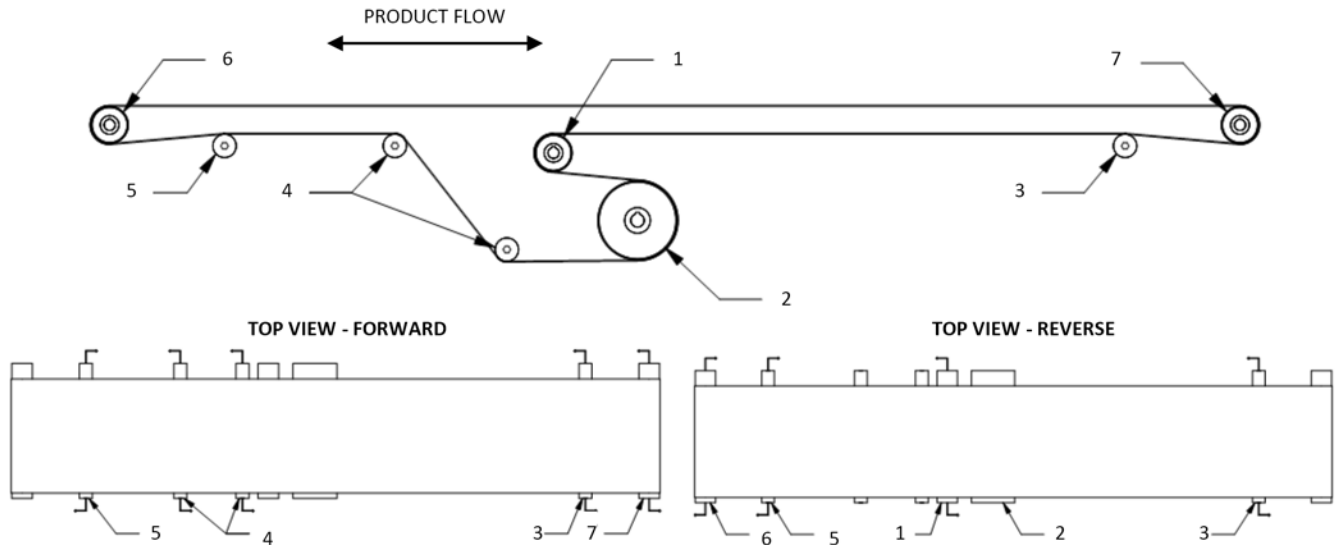

Note: If belt is running off-center to opposite than shown, adjust rollers and pulleys in opposite direction than shown.

FORWARD SERVICE

- 1) Start belt for FORWARD service. Run conveyor for a few minutes so the belt can take its position. **Stop conveyor immediately if belt rubs against side of conveyor.** If belt shifts to one side, adjust snub rollers (4) to steer belt to center of drive pulley (2), which in turn centers the belt onto the take-up pulley (7). Reversing belts may require that the belt run slightly off-center to one side in forward direction and to opposite side in reverse direction. This is due to the nature of the belt.
- 2) Slight adjustment of snub roller (3) may be required to steer the return belt to center of take-up pulley (7).
- 3) If belt is riding at the center of the take-up pulley (7) but not at the center of the take-up pulley (6), slight adjustment of take-up pulley (6) may be needed.

Note: Care is required as leading the belt with this pulley may cause the belt to travel to the opposite side in REVERSE service.

Adjust in very small increments. The belt will stretch during the first few days of operation. Adjust the take-up pulley (1) to compensate for the stretch.

REVERSE SERVICE

- 1) Tracking for REVERSE service should not be done until preliminary FORWARD service has been completed. If belt shifts to one side, adjust take-up pulley (1) to steer belt to center of drive pulley (2), which in turn centers the belt onto take-up pulley (6).
- 2) Slight adjustment of snub roller (5) may be required to steer belt to center of take-up pulley (6).
- 3) If belt is riding at the center of take-up pulley (6), but not at the center of take-up pulley (7), slight adjustment of take up pulley (7) may be needed.

Note: Care is required as leading the belt with this pulley may cause the belt to travel to the opposite side in FORWARD service. Adjust in very small increments.

- 4) Re-check belt for FORWARD direction. Repeat steps 1 through 3 as necessary making adjustments at each step in much smaller increments. The belt will stretch during the first few days of operation. Adjust the take-up pulley (1) to compensate for the stretch.

INSTRUCTIONS FOR BELT TRACKING: BELT TYPE 3

Note: All snub rollers and pulleys **must be** set square with the frame before making any belt tracking adjustments. Mark initial belt position before beginning. Make all adjustments in small increments. **CONVEYOR POWER MUST BE TURNED OFF WHEN MAKING ANY ADJUSTMENTS.** Do not overtighten the belt. Belt should be just tight enough to pull product load.

BELT TYPE 3: ONE-WAY SERVICE, INCLINED WITH NOSE-OVER AND END DRIVE

ELEVATION VIEW

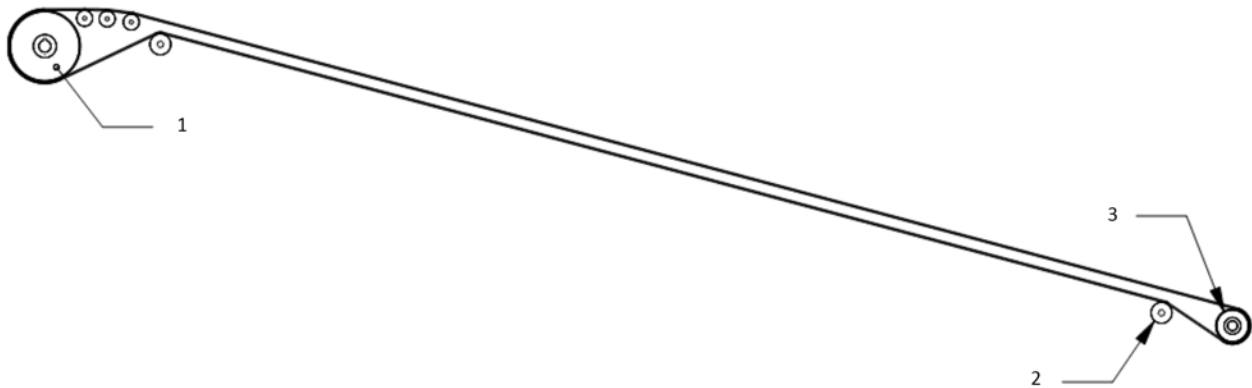

TOP VIEW

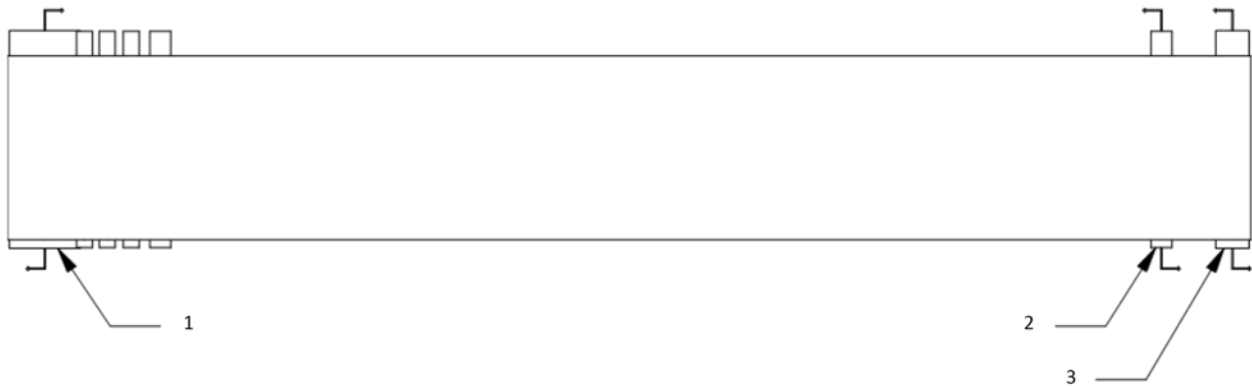

Note: If belt is running off-center to opposite than shown, adjust rollers and pulleys in opposite direction than shown.

- 1) Run conveyor for a few minutes so the belt can take its position. **Stop conveyor immediately if belt rubs against side of conveyor.** If belt shifts to one side, adjust snub roller (2) to steer belt to center of take-up pulley (3).
- 2) If belt is riding at the center of the take-up pulley (3) but not at the center of the drive pulley (1), adjust drive pulley (1) slightly as shown. The belt will travel toward the slack side.
- 3) Adjusting the drive pulley (1) may throw off belt alignment on the take-up pulley (3). Repeat steps 1 and 2 as necessary. The belt will stretch during the first few days of operation. Adjust the take-up pulley (3) to compensate for the stretch.

INSTRUCTIONS FOR BELT TRACKING: BELT TYPE 4

Note: All snub rollers and pulleys **must be** set square with the frame before making any belt tracking adjustments. Mark initial belt position before beginning. Make all adjustments in small increments. **CONVEYOR POWER MUST BE TURNED OFF WHEN MAKING ANY ADJUSTMENTS.** Do not overtighten the belt. Belt should be just tight enough to pull product load.

BELT TYPE 4: TWO-WAY SERVICE, INCLINED WITH NOSE-OVER AND CENTER DRIVE

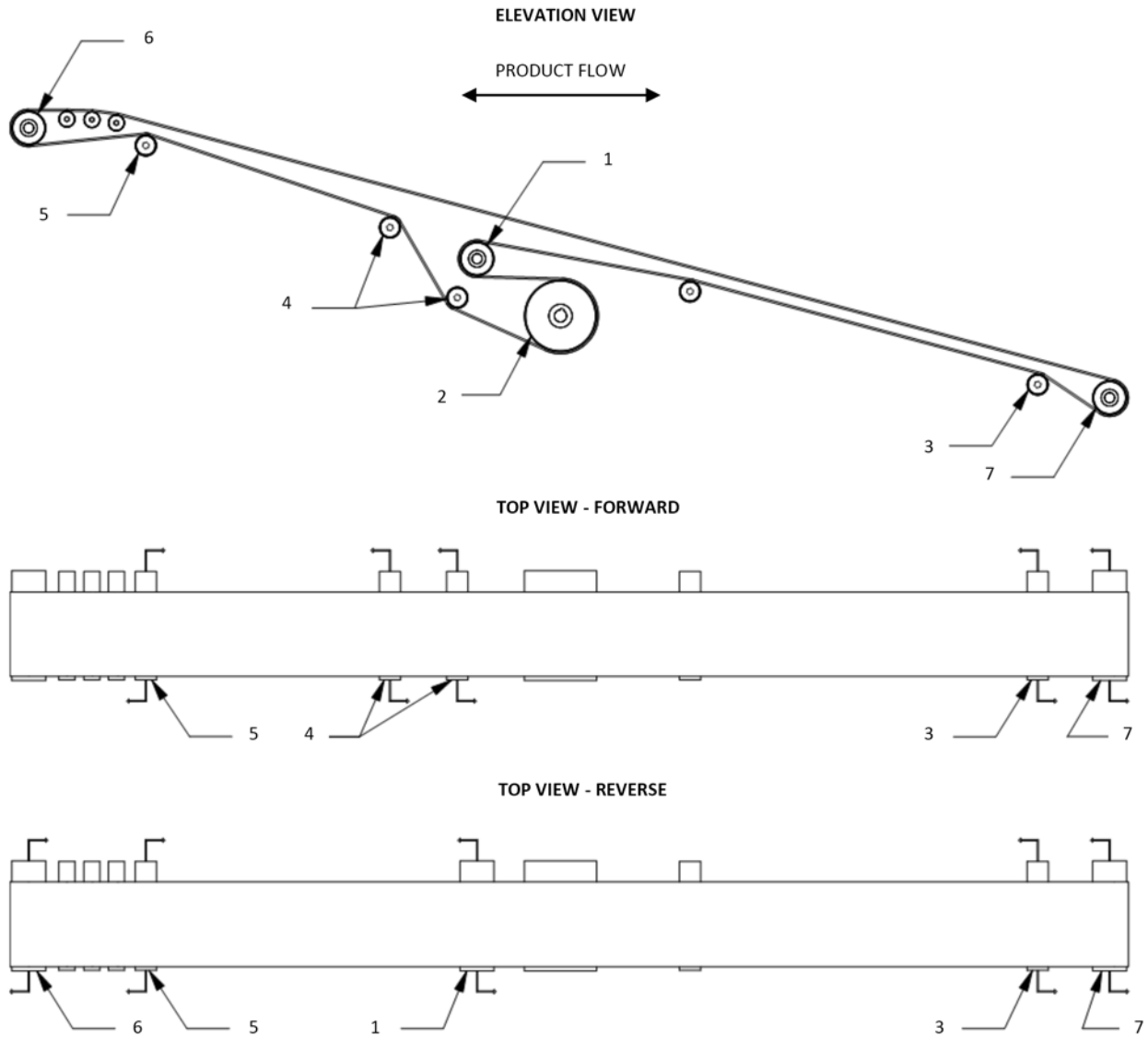

INSTRUCTIONS FOR BELT TRACKING: BELT TYPE 4

Note: All snub rollers and pulleys **must be** set square with the frame before making any belt tracking adjustments. Mark initial belt position before beginning. Make all adjustments in small increments. **CONVEYOR POWER MUST BE TURNED OFF WHEN MAKING ANY ADJUSTMENTS.** Do not overtighten the belt. Belt should be just tight enough to pull product load.

BELT TYPE 4: TWO-WAY SERVICE, INCLINED WITH NOSE-OVER AND CENTER DRIVE

FORWARD SERVICE

- 1) Start belt for FORWARD service. Run conveyor for a few minutes so the belt can take its position. **Stop conveyor immediately if belt rubs against side of conveyor.** If belt shifts to one side, adjust snub rollers (4) to steer belt to center of take-up pulley (2), which in turn centers the belt onto the take-up pulley (7). Reversing belts may require that the belt run slightly off-center to one side in forward direction and to opposite side in reverse direction. This is due to the nature of the belt.
- 2) Slight adjustment of snub roller (3) may be required to steer the return belt to center of take-up pulley (7).
- 3) If belt is riding at the center of the take-up pulley (7) but not at the center of the take-up pulley (6), slight adjustment of take-up pulley (6) may be needed.
Note: Care is required as leading the belt with this pulley may cause the belt to travel to the opposite side in REVERSE service.
Adjust in very small increments. The belt will stretch during the first few days of operation. Adjust the take-up pulley (1) to compensate for the stretch.

REVERSE SERVICE

- 1) Tracking for REVERSE service should not be done until preliminary FORWARD service has been completed. If belt shifts to one side, adjust take-up pulley (1) to steer belt to center of drive pulley (2), which in turn centers the belt onto take-up pulley (6).
- 2) Slight adjustment of snub roller (5) may be required to steer belt to center of take-up pulley (6).
- 3) If belt is riding at the center of take-up pulley (6), but not at the center of take-up pulley (7), slight adjustment of take up pulley (7) may be needed.
Note: Care is required as leading the belt with this pulley may cause the belt to travel to the opposite side in FORWARD service. Adjust in very small increments.
- 4) Re-check belt for FORWARD direction. Repeat steps 1 through 3 as necessary making adjustments at each step in much smaller increments. The belt will stretch during the first few days of operation. Adjust the take-up pulley (1) to compensate for the stretch.

INSTRUCTIONS FOR BELT TRACKING: BELT TYPE 5

Note: All snub rollers and pulleys **must be** set square with the frame before making any belt tracking adjustments. Mark initial belt position before beginning. Make all adjustments in small increments. **CONVEYOR POWER MUST BE TURNED OFF WHEN MAKING ANY ADJUSTMENTS.** Do not overtighten the belt. Belt should be just tight enough to pull product load.

BELT TYPE 5: TWO-WAY SERVICE, INCLINED WITH NOSE-OVER, CENTER DRIVE AND INFED SECTION

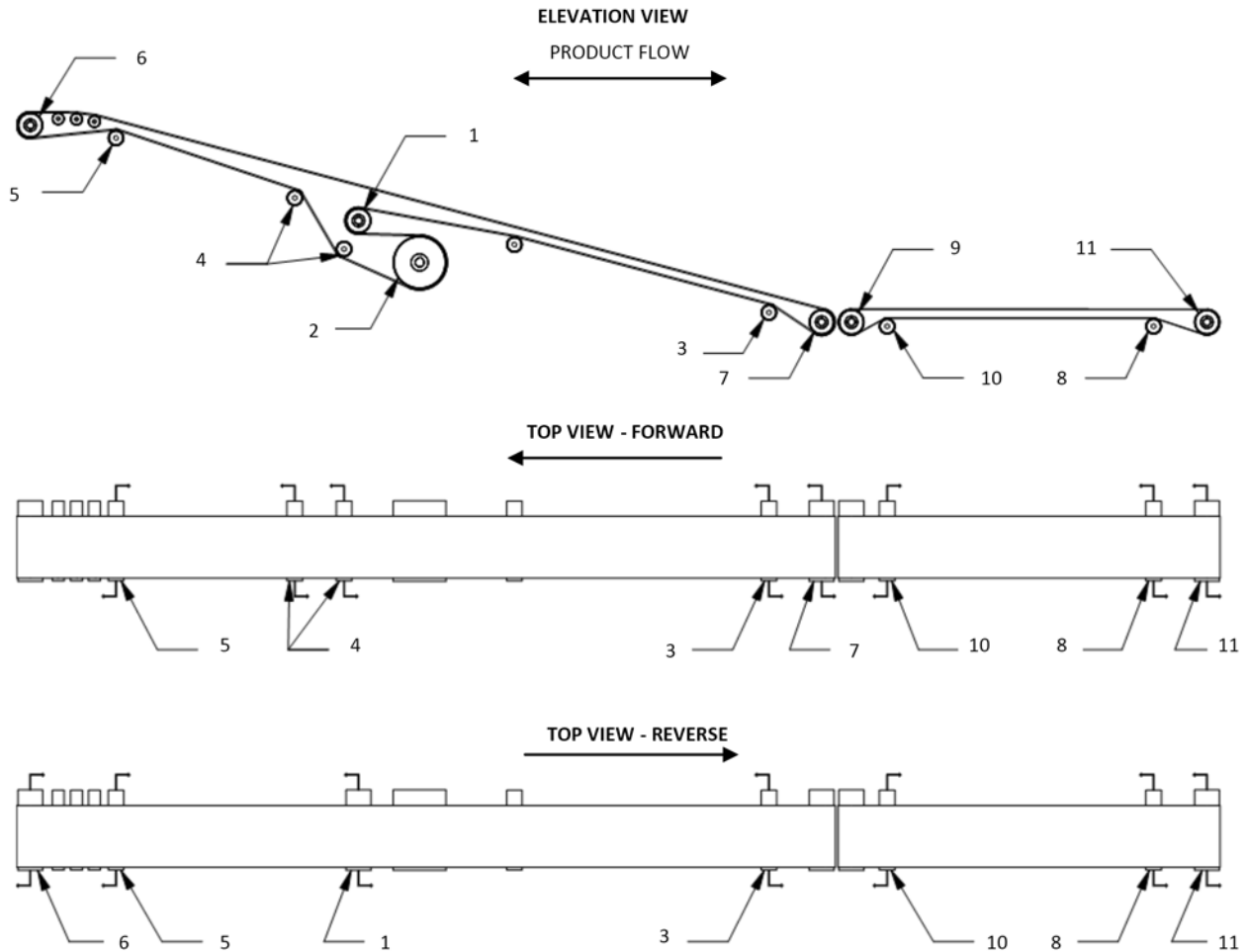

INSTRUCTIONS FOR BELT TRACKING: BELT TYPE 5

Note: All snub rollers and pulleys **must be** set square with the frame before making any belt tracking adjustments. Mark initial belt position before beginning. Make all adjustments in small increments. **CONVEYOR POWER MUST BE TURNED OFF WHEN MAKING ANY ADJUSTMENTS.** Do not overtighten the belt. Belt should be just tight enough to pull product load.

BELT TYPE 5: TWO-WAY SERVICE, INCLINED WITH NOSE-OVER, CENTER DRIVE AND INFEEED SECTION

FORWARD SERVICE

INCLINE CONVEYOR:

- 1) Start belt for FORWARD service. Run conveyor for a few minutes so the belt can take its position. **Stop conveyor immediately if belt rubs against side of conveyor.** If belt shifts to one side, adjust snub rollers (4) to steer belt to center of take-up pulley (2), which in turn centers the belt onto the take-up pulley (7). Reversing belts may require that the belt run slightly off-center to one side in forward direction and to opposite side in reverse direction. This is due to the nature of the belt.
- 2) Slight adjustment of snub roller (3) may be required to steer the return belt to center of take-up pulley (7).
- 3) If belt is riding at the center of the take-up pulley (7) but not at the center of the take-up pulley (6), slight adjustment of take-up pulley (6) may be needed.

Note: Care is required as leading the belt with this pulley may cause the belt to travel to the opposite side in REVERSE service.

Adjust in very small increments. The belt will stretch during the first few days of operation. Adjust the take-up pulley (1) to compensate for the stretch.

INFEEED CONVEYOR:

- 1) To track infeed section, adjust snub roller (8) to steer belt to the center of take-up pulley (11).
- 2) If belt is riding at the center of take-up pulley (11), but not at the center of the take-up pulley (9), snub roller (10) must be adjusted slightly. Additional skewing of take-up pulley (11) may be required.

Note: Care is required as leading the belt with this pulley may cause the belt to travel to the opposite side in REVERSE service.

Adjust in very small increments. The belt will stretch during the first few days of operation. Adjust the take-up pulley (11) to compensate for the stretch.

REVERSE SERVICE

DECLINE CONVEYOR:

- 1) Tracking for REVERSE service should not be done until preliminary FORWARD service has been completed. If belt shifts to one side, adjust take-up pulley (1) to steer belt to center of drive pulley (2), which in turn centers the belt onto take-up pulley (6).
- 2) Slight adjustment of snub roller (5) may be required to steer belt to center of take-up pulley (6).
- 3) If belt is riding at the center of take-up pulley (6), but not at the center of take-up pulley (7), slight adjustment of take up pulley (7) may be needed.

Note: Care is required as leading the belt with this pulley may cause the belt to travel to the opposite side in FORWARD service. Adjust in very small increments.

DISCHARGE SECTION:

- 1) To track discharge section, adjust snub roller (10) to steer belt to center of take-up pulley (9).
- 2) If belt is riding at the center of take-up pulley (9), but not at the center of take-up pulley (11), snub roller (10) must be adjusted slightly. Additional skewing of take-up pulley (9) may be required.

Note: Care is required as leading the belt with this pulley may cause the belt to travel to the opposite side in FORWARD service.

- 3) Re-check belt for FORWARD direction. Repeat steps 1 through 3 as necessary making adjustments at each step in much smaller increments. The belt will stretch during the first few days of operation. Adjust the take-up pulley (11) to compensate for the stretch.

GENERAL INSTALLATION: BELT CURVE TENSIONING

BELT CURVE TENSIONING INSTRUCTIONS

Note: Do not over tension belting.

This will result in excessive stress in the guide system.

Disconnect power before removing guards.

To ensure long life and proper wear of guiding system, there should be a periodic inspection of the belt. The belt should be adjusted if the drive pulley is slipping or there are waves across the full width of the belt. If tensioning is required disconnect the power and remove the guiding system cover to observe guide wheel contact with the guide track.

After removing the cover, loosen the bearing bolts so the bearings can be adjusted using the jack screws. To tension the belt, begin by adjusting the outside bearings. Adjust the bearings toward the ends of the conveyor maintaining equal adjustments in relation to each end.

After slight tensioning of the belt, check the guide wheels. They should be entering and exiting the guides with at least 1/16" gap. By hand, try to rotate each wheel along the guide. If a wheel fails to rotate by hand, there is too much tension on the guiding system. Beware of dangerous moving parts.

When the outside is tensioned, the inside should be done as well while checking the tension throughout the belt width. After tensioning is complete, tighten all bearing bolts and replace guiding system cover.

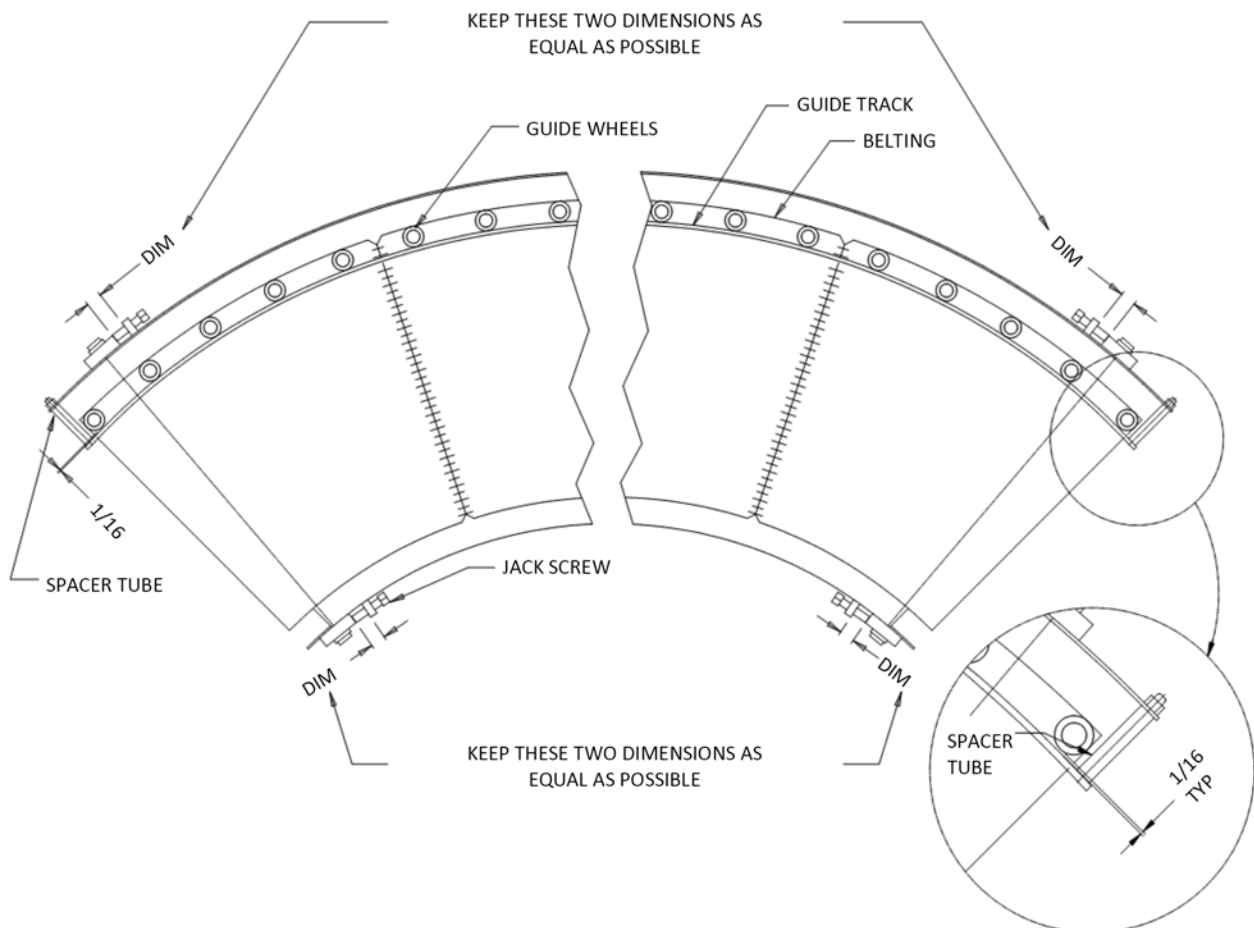

PRE-START-UP OVERVIEW: PREPARING FOR INITIAL START-UP

- 1) Review pages 7 through 12 prior to starting any equipment.
- 2) Verify that conveyor sections, leg supports, etc. were installed properly.
- 3) Verify that drive chains and sprockets are installed, aligned and tensioned properly.
- 4) Verify set screws are tight in sprockets, bearings and all components that have them in.
- 5) Verify that all drive and mounted bearing bolts are fastened securely.
- 6) Verify that all motor control wiring is connected properly.
- 7) Verify that conveyor is not loaded with product.
- 8) Verify that gearboxes are filled with the proper amount of oil or that they were factory filled with lube. (If your conveyor is equipped with a Boston 700 Series Reducer, it is filled with oil, sealed and lubed for life thus requiring no oil changes. Literature provided with equipment will give detailed info on gearbox lube info.)
- 9) Verify that the gearbox has necessary vent plugs installed if applicable. (If your conveyor is equipped with a Boston 700 Series Reducer, it is supplied with a PosiVent® and no vent plug is required. Literature provided with equipment will give detailed info on gearbox vent plug requirements.)

PRE-START-UP OVERVIEW: DRIVE CHAIN AND SPROCKET ALIGNMENT

DRIVE CHAIN AND SPROCKET ALIGNMENT

To achieve maximum service life and efficiency from a chain drive, follow these simple guidelines:

- Visually inspect the roller chain, sprockets, and other components and verify that they are in good condition.
- Ensure that the sprockets are properly aligned.
- Adequately lubricate the chain.
- Inspect for proper chain tension.

CONDITION OF COMPONENTS

Shafting and bearings should be supported rigidly to maintain the initial alignment.

Roller chain should be free of grit and dirt. Wash chain in kerosene when required. Relubricate.

DRIVE ALIGNMENT

Misalignment results in uneven loading across the width of the chain and may cause roller link-plate and sprocket tooth wear. Drive alignment involves two things: parallel shaft alignment and axial sprocket alignment.

ALIGNING SHAFTS

Shafts should be parallel and level. If there is axial movement of the shaft (as in the case of an electric motor), lock the shaft in the normal running position before aligning the sprockets.

ALIGNING SPROCKETS

Sprocket axial alignment can be checked with a straight edge which will extend across the finished sides of the two sprockets. Normally, it is good practice to align the sprockets as close to the shaft bearing as possible. For long center distances, use a taut cord, or wire long enough to extend beyond each of the sprockets.

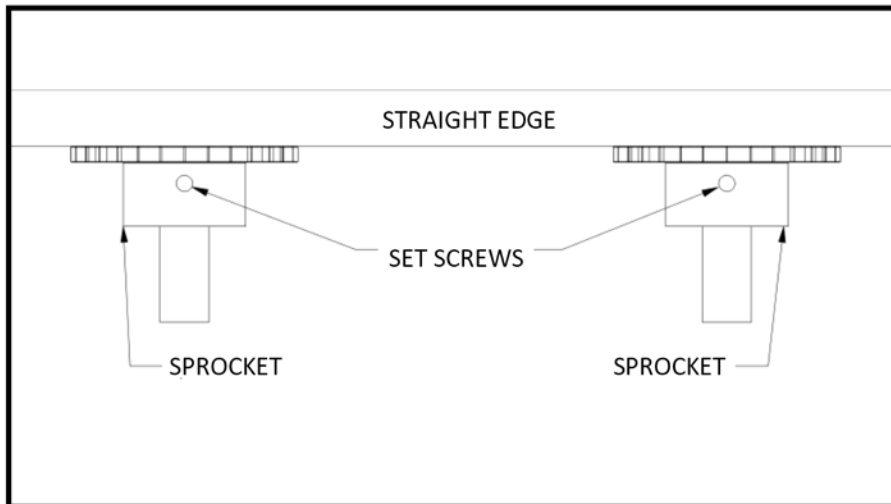

WARNING:

Before performing any maintenance, lubrication or inspection on any powered conveyor, the electrical power must be turned off and locked / tagged out following your company's machine specific procedure. **NEVER** operate the conveyor with any guard removed.

PRE-START-UP OVERVIEW: DRIVE CHAIN AND SPROCKET TENSION

INSTALLING THE CHAIN

Recheck all preceding adjustments for alignment and make certain all set screws, bolts and nuts are tight. Fit chain around both sprockets and bring the free ends together on one sprocket for connection. The sprocket teeth will locate the chain end links. Install the connecting link, connecting link cover plate and the spring clip or cotter pins. On larger pitch chains or heavy multiple strand, it may be necessary to lock the sprockets for this operation.

CHAIN TENSION

Check chain tension to be certain the slack span has an approximate 2% mid-span movement.

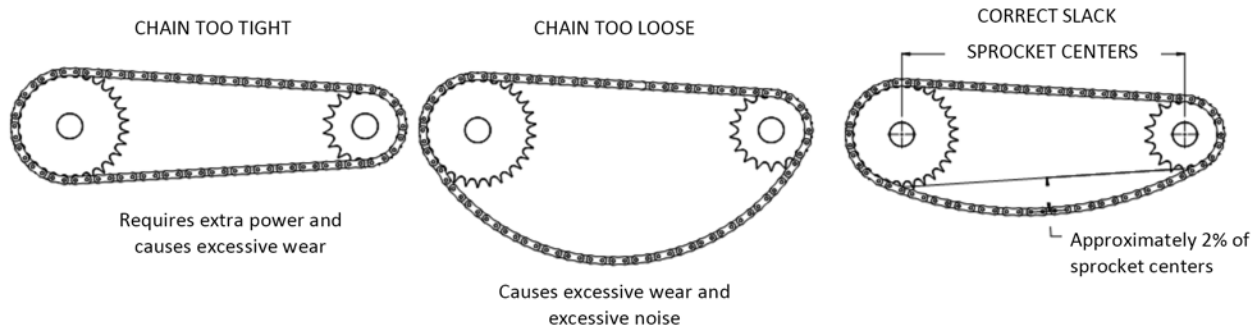

PRE-START-UP OVERVIEW: GEAR REDUCER VENT PLUG

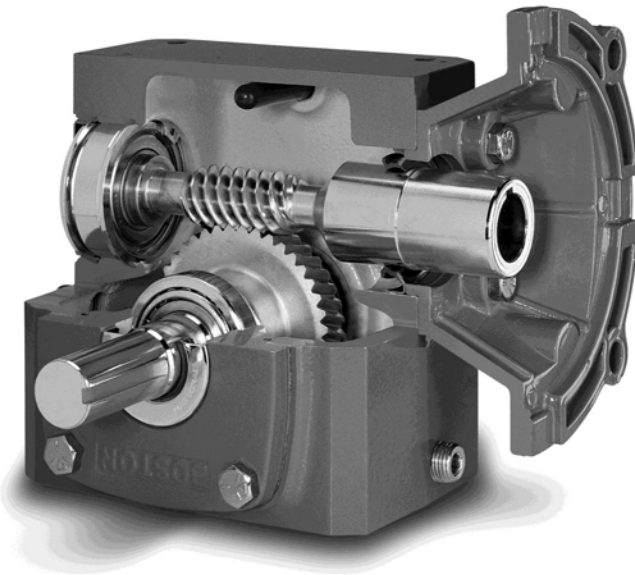

PosiVent®

Omni Metalcraft Corp. standardly supplies the Boston Gear PosiVent® option for all current 700 series styles and configurations. This specially-designed internal pressure equalization system allows the gearbox to operate in all environments without the use of conventional pressure vents. The unique design comes complete with Klubersynth UH1 6-460 lubrication pre-filled for all mounting positions. Unlike competitive versions, this unique single seam design allows for easy installation and extended life. This means longer trouble-free operation with virtually no maintenance.

CARE AND MAINTENANCE OF CHAIN

Proper maintenance of any chain should include correct lubrication, periodic inspection and proper adjustment for normal wear. Periodic inspection of the chain and sprockets is required to detect any deviation from normal wear before serious damage takes place. The cost of such inspection is repaid many times in extended chain life and in freedom from failure. No general rule can be given for the frequency of inspection. The frequency should be influenced by conditions of operation.

CHAIN LUBRICATION AND ENVIRONMENT

One of the most important factors in getting the best possible performance out of our drive chain is proper lubrication. A well lubricated chain will have an operating life much longer than that of an unlubricated chain. Wear between the pin and bushing causes drive chain to elongate. These parts should, therefore, be well lubricated. The gap between the roller link plate and the pin link plate on the slack side of the chain should be filled with oil. This oil forms a film which minimizes wear on the pin and bushing, thus increasing the chain's service life. It also reduces noise and acts as a coolant when the chain runs at high speeds.

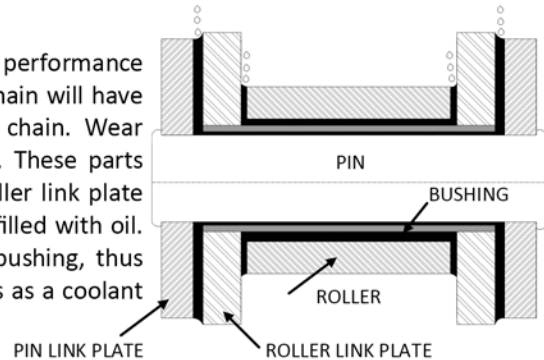

Clean Atmosphere: Chains operating in a relatively clean atmosphere can be lubricated by brush or drip-feed oilers or by applying the lubricant manually with a brush or oil can.

Atmosphere with Lint or Non-Abrasive Dust: Where large volumes of lint or non-abrasive dust are present, a brush or wiper can be used to clean the chain and apply a lubricant. Otherwise the lint or dust will clog the chain joint clearance and prevent penetration of the oil into the joints.

Abrasive Atmosphere: If abrasives come in contact with chain, lubrication becomes more difficult. When lubricants are applied externally, abrasive particles tend to adhere to the chain surfaces and act as a lapping or grinding compound. Under extreme conditions it is sometimes advisable to avoid chain lubrication.

Extreme Conditions: Consult a lubricant manufacturer when chains are required to operate at temperatures outside of those indicated in the chart below or if chains are used in other extreme conditions.

SUGGESTED LUBRICATION

Only high quality oil should be used to lubricate chain. Neither heavy oil nor grease is suitable. The lubricant should have a viscosity to enable it to reach internal surfaces under normal conditions. Lubricants suggested for specific ambient temperatures and chain speed ranges are given in the table below.

CHAIN NUMBER	TEMPERATURE			
	15° - 35° F	35° - 105° F	105° - 120° F	120° - 140° F
ANSI 25 - 50	SAE10W	SAE20	SAE30	SAE40
ANSI 60 - 100	SAE20	SAE30	SAE40	SAE50
ANSI 120 - 240	SAE30	SAE40	SAE50	
4" & 6" PITCH (ENGINEERED CHAIN)	SAE20	SAE30		SAE40

MAINTENANCE: MAINTENANCE SCHEDULES

Note:

Review pages 10 and 11 prior to maintaining any equipment.

If equipment repair or replacement is required during inspections, thoroughly review the manufacturer's specific product information for correct procedure.

DAILY MAINTENANCE

- Inspect all conveyors to ensure that all guarding is securely in place.
- Inspect belt tracking for at least (3) full belt revolutions.

WEEKLY MAINTENANCE

- Inspect conveyor for loose bolts and set screws.
- Inspect bearings, gear reducers, motors and chains for excessive noise or heat.
- Inspect belt to ensure that there is not excessive wear and that all splices are intact.
- Inspect belt tension. The tension should be enough to:
 - A) Prevent slippage between drive pulley (sheaves for spurs) and belt under a full load.
 - B) Force belt to conform to the crown on crowned pulleys.
- Inspect rollers to ensure that they rotate freely without excessive noise.

MONTHLY MAINTENANCE

- Inspect oil level in reducer. Fill if necessary.
- Inspect reducer for leaking seals.
- Inspect conveyor for loose bolts.
- Inspect drive chains, jump chains and sprockets for wear, alignment and proper chain tension. For chain lubrication see page 40.
- Check guide system wheels to ensure all bearings are intact and wheel covers are not worn through on belt curves.
- Lubricate pulley shaft bearings. Use No. 2 lithium base grease or equivalent.

QUARTERLY MAINTENANCE

- Grease all pulley shaft bearings.
- Inspect conveyors for worn or broken drive belts. Replace as necessary. If belt shows signs of abrasion, check for hindrance with the belt or foreign object in the roller groove.

SEMI-ANNUAL MAINTENANCE

- Tighten all bearing set screws if not completely tight.

ANNUAL MAINTENANCE

- Change oil in reducers. (If your conveyor is equipped with a Boston 700 Series Reducer, it is filled with oil, sealed and lubed for life thus requiring no oil changes. See manufacturer's information for recommended lubricant at specific temperatures. This information is shipped with every reducer.)

MAINTENANCE: REPORT ON MISCELLANEOUS MAINTENANCE PERFORMANCE

REPORT ON MISCELLANEOUS MAINTENANCE PERFORMANCE

Date _____

Maintenance Performed:

Date _____

Maintenance Performed:

Date _____

Maintenance Performed:

Date _____

Maintenance Performed:

Date _____

Maintenance Performed:

Date _____

Maintenance Performed:

Date _____

Maintenance Performed:

TROUBLESHOOTING AND REPLACEMENT PARTS: TROUBLESHOOTING

TROUBLE	CAUSE	SOLUTION
Conveyor not starting or motor stalling	Motor is overloaded	Check conveyor load. Remove excessive load.
	Motor is drawing excessive current	Check circuit breaker
Excessive drive chain/ sprocket wear	Inadequate lubrication	Apply chain lubricant
	Misaligned sprockets	Align sprockets
	Loose drive chain	Tension drive chain
Loud popping or grinding noise	Faulty bearing	Replace bearing
	Loose drive sprocket set screw	Tighten set screw and check key
	Loose drive chain	Tension drive chain
Motor and gear reducer makes excessive noise	Damaged gears	Replace unit
	Faulty bearing	Replace bearing
Motor or reducer overheating	Conveyor overloaded	Check conveyor load. Remove excessive load.
	Low voltage to motor	Correct voltage level
	Reducer lubricant level low	Fill reducer reservoir
Drive pulley turns but belt does not move or moves with a jerky motion	Conveyor overloaded	Check conveyor load. Remove excessive load.
	Loose conveyor belt	Tighten conveyor belt
	Belt installed upside down	Install belt right side up
Belt slips and squeals	Loose conveyor belt	Tighten conveyor belt
Portion of belt creeps to one side	Belt ends not square	Use T-Square to cut ends of belt squarely and re-install
	Belt is bowed	Allow new belt to "break in"
		If belt is "broke in", replace with a new belt
Excessive belt stretch	Belt over tensioned	Reduce belt tension. Check drive pulley for proper lagging.
Belt creeps to one side of head pulley	Head pulley or idlers preceding are out of alignment	Realign by advancing (adjust in the direction of belt travel) the end of the end of the pulley or idler to which the belt has shifted
Belt creeps to one side at one spot along the length of conveyor	One or more idlers preceding the trouble spot are out of alignment	Realign by advancing (adjust in the direction of belt travel) the end of the idler to which the belt has shifted
	Improper loading of belt	Center load on belt
	Frozen idlers	Replace idlers
	Conveyor frame out of square or not level	Square and level conveyor frame
	Debris build up on pulleys or idlers	Remove debris from pulleys or idlers

PARTS LISTS: BELT STRAIGHT ROLLER BED

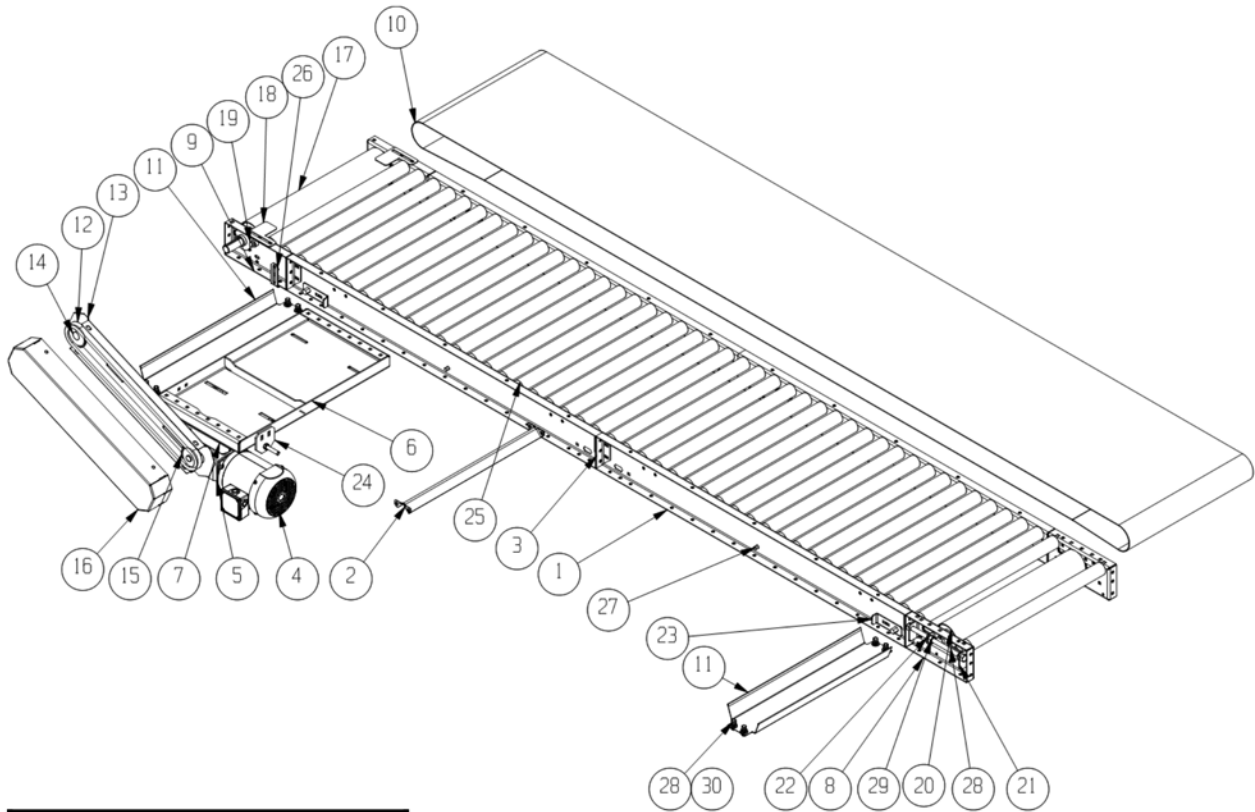

DETAIL	DESCRIPTION
1	SIDEFAME
2	BOLT-IN SPREADER
3	END COUPLER
4	MOTOR
5	REDUCER
6	DRIVE SUPPORT
7	CARRIAGE PLATE
8	TAKE-UP SIDEFAME
9	DRIVE SIDEFAME
10	BELT
11	SNUB ROLLER GUARD
12	DRIVE CHAIN
13	BACK CHAIN GUARD
14	DRIVEN SPROCKET
15	DRIVE SPROCKET
16	FRONT CHAIN GUARD
17	DRIVE PULLEY
18	FINGER GUARD
19	BEARING
20	TAKE-UP PULLEY
21	TAKE-UP BASE PLATE
22	TAKE-UP ADJUSTMENT BRACKET
23	SNUB ROLLER BRACKET
24	JACK SCREW BRACKET
25	GRAVITY ROLLER
26	GUARD SUPPORT BRACKET
27	RETURN GRAVITY ROLLER
28	HEX HEAD CAP SCREW
29	JAM NUT
30	WHIZ NUT

PARTS LISTS: BELT STRAIGHT SLIDER BED

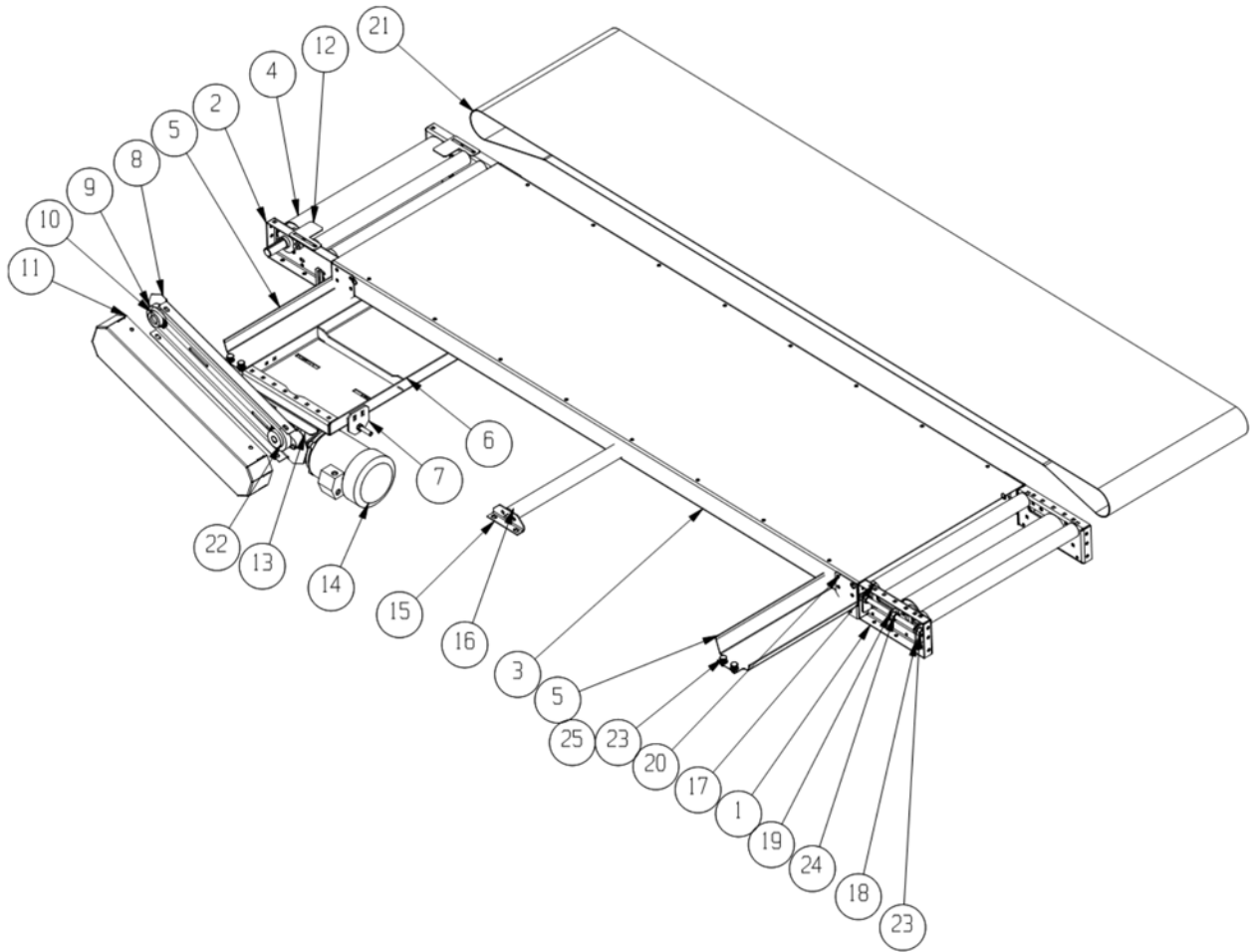

DETAIL	DESCRIPTION
1	TAKE-UP SIDEFRAME
2	DRIVE SIDEFRAME
3	INTERMEDIATE FRAME
4	DRIVE PULLEY
5	SNUB ROLLER GUARD
6	DRIVE SUPPORT
7	JAKE SCREW BRACKET
8	BACK DRIVE GUARD
9	DRIVE CHAIN
10	DRIVEN SPROCKET
11	FRONT GUARD
12	FINGER GUARD
13	REDUCER
14	MOTOR
15	ROLLER MOUNTING BRACKET
16	RETURN GRAVITY ROLLER
17	GRAVITY ROLLER
18	TAKE-UP BASE PLATE
19	TAKE-UP ADJUSTMENT BRACKET
20	GUSSET
21	BELT
22	DRIVE SPROCKET
23	HEX HEAD CAP SCREW
24	JAM NUT
25	WHIZ NUT

BELT CONVEYOR STRAIGHT, CURVE AND INCLINED TECH HANDBOOK
PARTS LISTS: BELT INCLINE STYLE 1 SLIDER BED

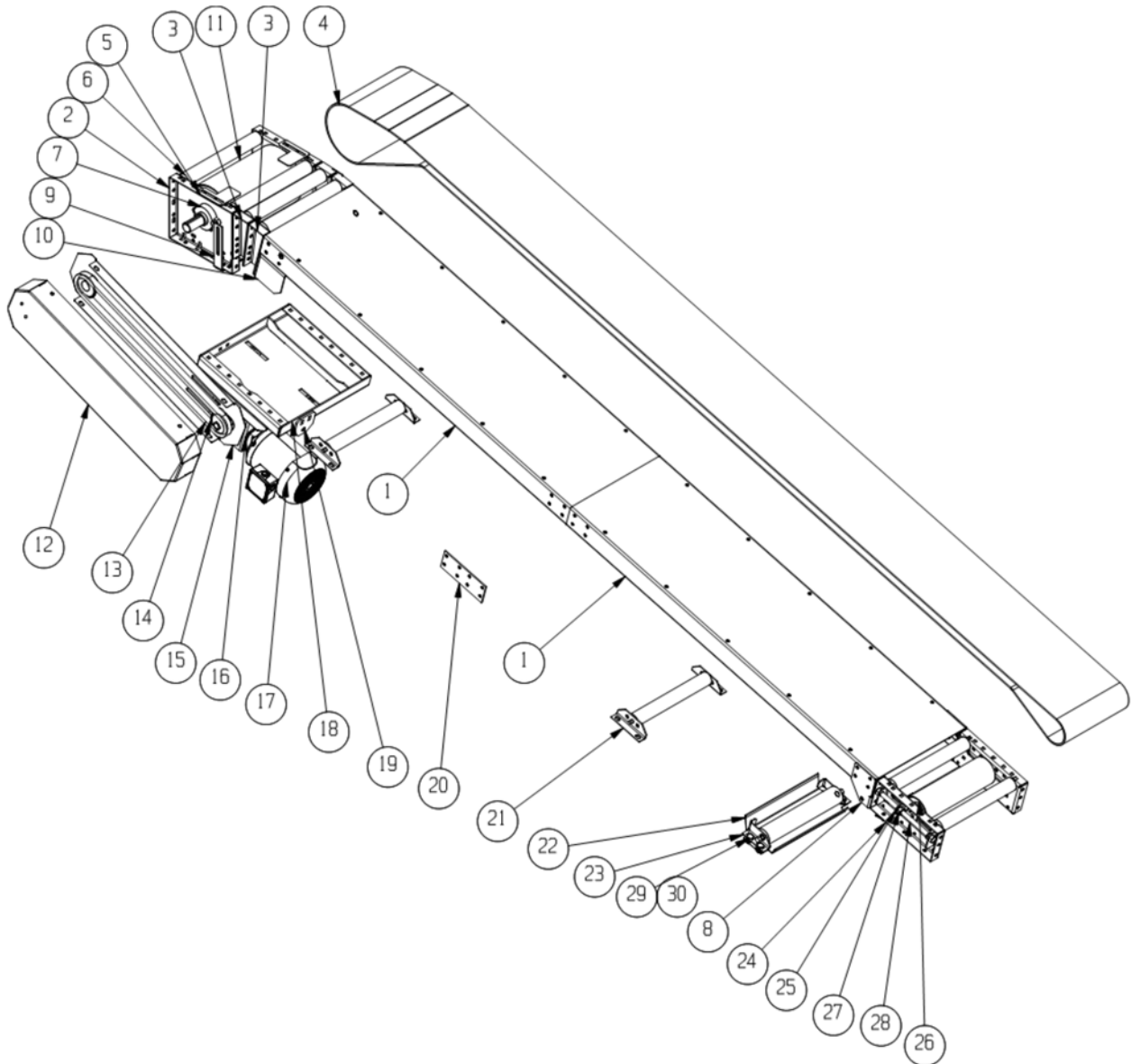

DETAIL	DESCRIPTION	DETAIL	DESCRIPTION
1	SLIDE PAN	16	REDUCER
2	DRIVE END SIDEFRAME	17	MOTOR
3	NOSE OVER	18	DRIVE SUPPORT BASE
4	BELT	19	JACK SCREW BRACKET
5	FINGER GUARD	20	SPLICE PLATE
6	GRAVITY ROLLER	21	ROLLER BRACKET
7	BEARING	22	SNUB ROLLER GUARD
8	FORMED GUSSET	23	SNUB ROLLER BRACKET
9	GUARD SUPPORT BRACKET	24	TAKE-UP SIDE FRAME
10	FORMED RIB	25	ADJUSTMENT BRACKET
11	DRIVE PULLEY	26	TAKE-UP PULLEY
12	FRONT CHAIN GUARD	27	JAM NUT
13	DRIVE CHAIN	28	HEX HEAD CAP SCREW
14	DRIVEN SPROCKET	29	FLAT WASHER
15	BACK CHAIN GUARD	30	WHIZ NUT

PARTS LISTS: BELT INCLINE STYLE 2 SLIDER BED/ DECLINE STYLE 3 SLIDER BED

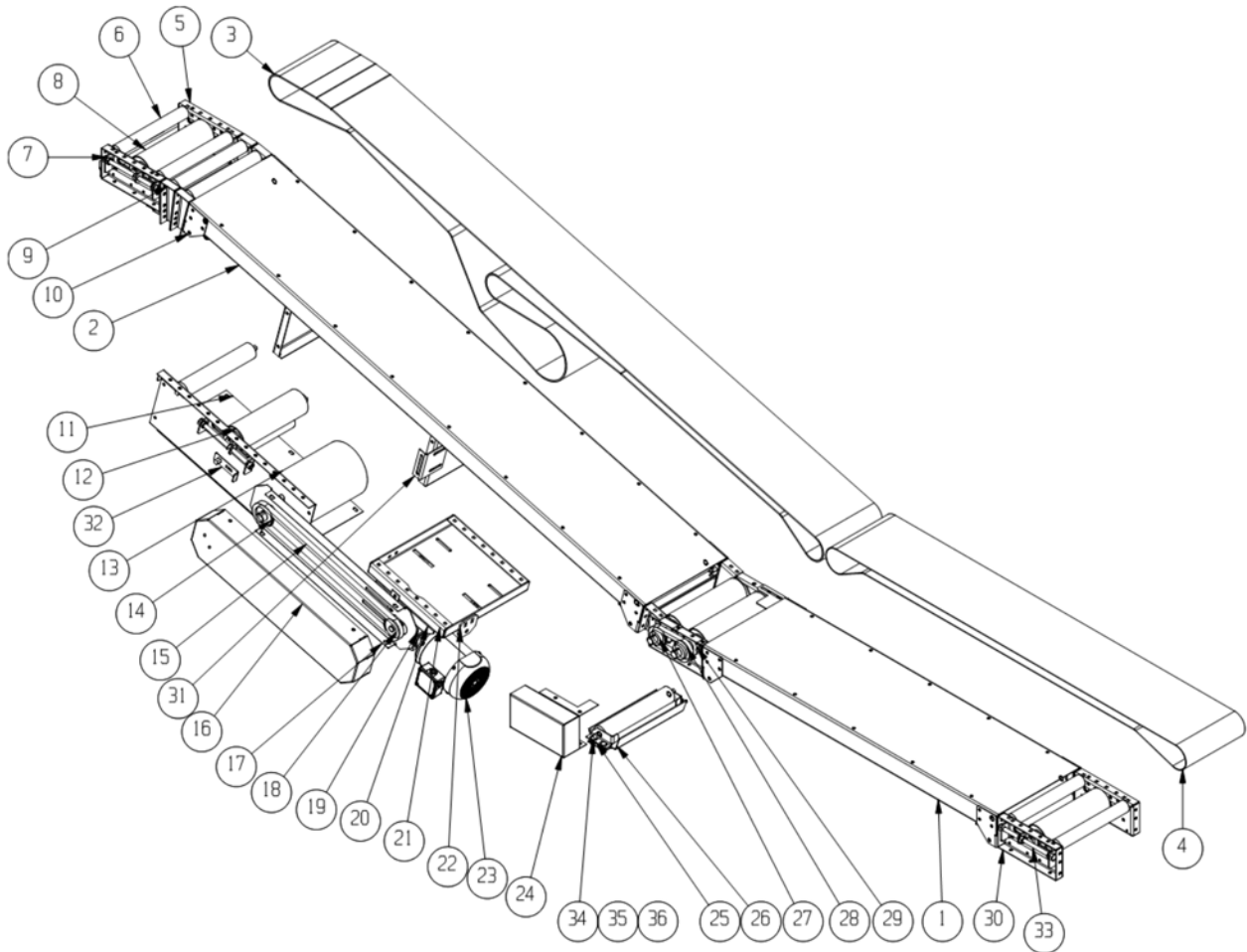

DETAIL	DESCRIPTION	DETAIL	DESCRIPTION
1	INFEED SLIDE PAN	19	REDUCER
2	INCLINE SLIDE PAN	20	CARRIAGE PLATE
3	INCLINE BELT	21	DRIVE SUPPORT BASE
4	INFEED BELT	22	JACK SCREW BRACKET
5	TAKE-UP SIDEFRAME	23	MOTOR
6	GRAVITY ROLLER	24	POWER TAKE-OFF GUARD
7	ADJUSTMENT BRACKET	25	SNUB ROLLER BRACKET
8	TAKE-UP PULLEY	26	SNUB ROLLER GUARD
9	NOSE OVER	27	SLAVE SPROCKET
10	FORMED GUSSET	28	SLAVE ROLLER CHIAN
11	BOTTOM COVER	29	BEARING
12	IDLER PULLEY	30	INFEED TAKE-UP SIDEFRAME
13	DRIVE PULLEY	31	DRIVE GUARD BRACKET
14	DRIVEN SPROCKET	32	SNUB ROLLER ADJUSTMENT BRACKET
15	DRIVE ROLLER CHAIN	33	HEX HEAD CAP SCREW
16	FRONT CHAIN GUARD	34	CARRIAGE BOLT
17	BACK CHAIN GUARD	35	FLAT WASHER
18	DRIVE SPROCKET	36	WHIZ NUT

ABBREVIATED WARRANTY

Omni Metalcraft Corp. warrants that the Equipment will be free of defects in workmanship and material (if properly installed, operated and maintained) for a period of one year or 2080 hours of use, whichever is sooner, from date of shipment to Customer, subject to the limitations hereunder set forth. If within the one year warranty period, Omni receives from the Customer written notice of any alleged defects in the Equipment and if the Equipment is not found to be in conformity with this warranty (the Customer having provided Omni a reasonable opportunity to perform any appropriate tests thereon) Omni will, at its option, either repair the Equipment or supply a replacement therefore.

*The above stated information is in reference to a section of Omni Metalcraft's full Terms and Conditions of sale. This information does not constitute an agreement, but simply reference information. To obtain a full copy of Omni Metalcraft's Terms and Conditions of Sale, please contact your Sales Representative.

OmniMetalcraftcorp.

P.O. Box 352 ■ Alpena, Michigan 49707
Phone 989.358.7000
Fax 989.358.7020
info@omni.com