

# CANTILEVER RACK INSTALLATION INSTRUCTIONS

We at Bulldog Rack Company would like to thank you for your order! To ensure a safe installation, please read through all these instructions prior to starting assembly. Should you have a question about installation, please feel free to contact your local sales representative. We thank you in advance for following these simple steps to ensure a safe assembly.

## CONCRETE FOUNDATION REQUIREMENTS

Foundations must be designed using load specifications, soil conditions, seismic concerns and local codes and requirements. BULLDOG requires a minimum thickness of 6" for proper anchoring and the concrete must extend a minimum of 6" from the end of the base and 6" from the face of the column for single-sided cantilever

Floors and slabs on grade must maintain a surface flatness of 1/4" maximum in 10 feet. BULLDOG is not responsible for the concrete design or flatness

## BASIC PERSONNEL REQUIREMENTS FOR INSTALLATION

Because the forklift will do most of the heavy work, the number of personnel to effect a timely installation can vary. For a safe environment and a timely assembly, we recommend one or more crews of four people, supervised by a member of management. Your local sales representative may be available to be on hand for the installation. However, please call in advance to schedule this.

## TOOL AND EQUIPMENT REQUIREMENTS

The following are a list of tools and equipment necessary for assembly and anchoring. Have these available at startup.

ASSEMBLY	ANCHORING
3/4" Spud Wrench or 3/4" Electric or Pneumatic Impact Wrench <sub>1</sub>	1/2" Drive Hammer Drill (dust blower)
1-1/8" Impact Socket	3/4" x 18" Masonry Drill Bit <sub>2</sub>
1-1/8" Comb. Box/Open End Wrench	1-1/8" Comb. Box/Open End Wrench <sub>2</sub>
100' 12 gauge Extension Cord (or compressor and hose)	100' 12 gauge Extension Cord
Tape Measure	Tape Measure
Chalk and Chalk-Line	Chalk and Chalk-Line
Carpenter Crayon or Pencil	Carpenter Crayon or Pencil
Forklift with Reach Height to Top of Column	Piece of Rebar (to tap in anchor through top flange of base)
	2# Sledge

- 1- Using an impact wrench will speed up the tightening of all nut and bolt connections dramatically.
- 2- 3/4" diameter anchors x 4-3/4" long are the minimum standard size. 3/4" diameter anchors x 5-1/2" long may also be used.

## INVENTORY OF COMPONENTS

Using the packing list, locate and inventory all goods including bolt/nut carton count and loose hardware to insure receipt of all merchandise. Please contact your representative if you have questions upon receipt of racking.

## SAFETY EQUIPMENT

Back braces, gloves and good steel-toed shoes for all personnel are recommended. Hardhats help to prevent subtle bumps and mishaps. Additionally, tethers or belts to secure personnel working off the floor during assembly are highly recommended. We also recommend an adequate timeframe without interruption to working installers to ensure their safety from disruption of concentration.

## DESCRIPTION OF COMPONENT PARTS

The following illustrations and descriptions are provided for easy identification of the cantilever component parts.

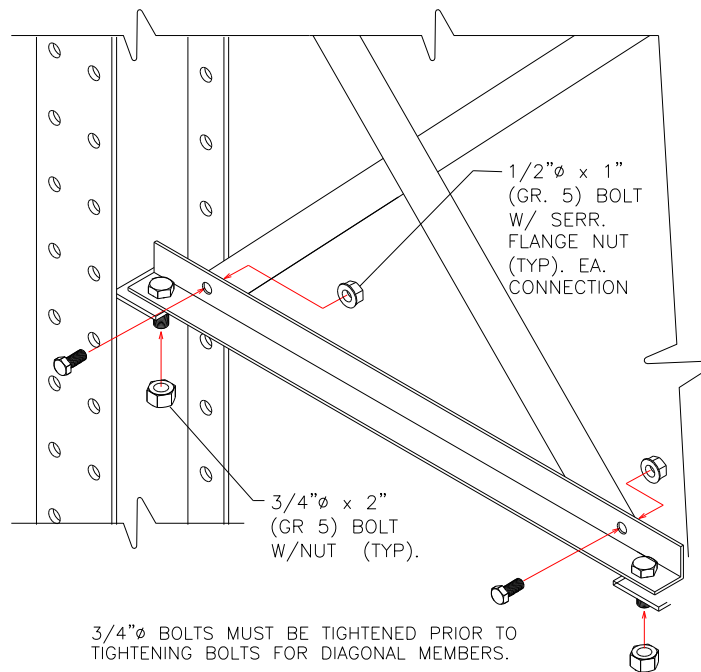
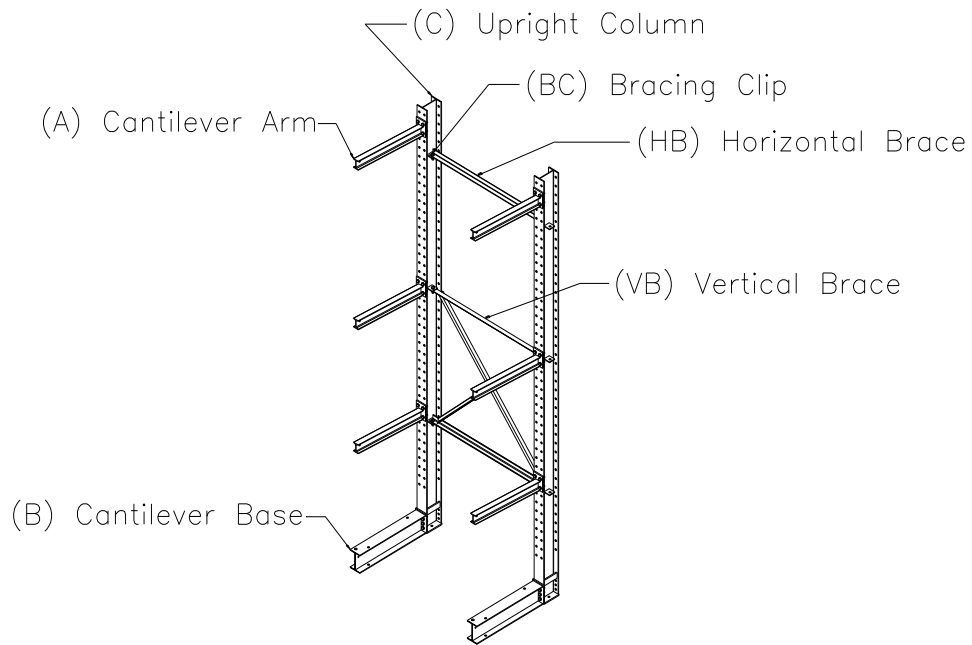

**Cantilever Knockdown Vertical Bracing (BBP)**

**(A) Cantilever Arm** – Projects from the column, adjustable vertically at 4" on-center multiples. The arm pitch is typically 3/4" per foot. Four bolts/nuts are required to attach the cantilever arms to the upright column.

**(B) Cantilever Base** – At floor level, mounted to face of upright column, same size steel as column.

**(C) Upright Column** – Single-sided cantilever has a base and arms attached to one side only. Double-sided cantilever has a base and arms attached to both sides. Holes are factory punched, 4” on-center, on both sides.

**(BC) Bracing Clip** – Pre-punched and factory welded onto upright column to receive the vertical brace and horizontal brace.

**(BBP) Knock Down Vertical Brace** – Pre-punched and field-assembled “X” brace (consisting of (2) angles to be used as horizontal members and (2) flat straps to be used as diagonal members) for bolting to bracing clips.

**(HB) Horizontal Brace** – Pre-punched brace for bolting to bracing clip on upright column exceeding 12’ in height, or in alternating bays to “X” bracing (as specified).

#### OPTIONAL ITEMS

**(EC) End Cap** – Optional protective cap softens impact and minimizes injury to personnel.

**(RP) Retaining Pole** – Retainer that is located in the pole socket on the cantilever arms or in the pole socket on the cantilever base. Assists in preventing “pitch forward” of materials stored loosely.

**(PS) Pole Socket** – Socket bracket assembly that accepts retaining pole. The Pole Socket bolts to the end of the cantilever arm.

**(SH) Cantilever Arm Sign Holder** – Attaches to the arm for product identification where it is important to sign various materials.

#### RACK INSTALLATION PROCEDURE

1. Lay two **Upright Columns** parallel to each other on the ground with holes facing up, set apart to accept the **Vertical Brace**. The ends of the columns should be even. The bottom of upright has a plate attached.
2. Lay **Vertical Brace** in place between **Upright Columns**. **Vertical Brace** rests between (2) sets of bracing clips. Attach with the  $\frac{3}{4}$ ” diameter grade 5 nuts/bolts provided. Tighten bolts to  $\frac{1}{2}$  turn from snug tight or to 200 to 250 ft.-lbs. torque. (Snug tight is defined as the tightness that exists when the plies of steel are in firm contact. This is accomplished with a few impacts of an impact wrench of the full effort of a man using an ordinary spud wrench.)  
  
**(CKVBA).** Lay **2 Horizontal Members of Vertical Brace** in place between **Upright Columns**. Attach with the  $\frac{3}{4}$ ” diameter grade 5 nuts/bolts provided. Mount Diagonal Members to the Horizontal Members as shown above with  $\frac{1}{2}$ ” diameter grade 5 nuts/bolts provided. Tighten the  $\frac{3}{4}$ ” diameter bolts to  $\frac{1}{2}$  turn from snug tight or to 200 to 250 ft.-lbs. Torque. and then tighten the  $\frac{1}{2}$ ” diameter bolts to  $\frac{1}{2}$  turn from snug tight or to 200 to 250 ft.-lbs. Torque.
3. Locate and attach **Horizontal Brace** for uprights 13’ to 17’. For columns over 17’, there is an additional X-brace. Brace rests on upper bracing clips, above **Vertical Brace**. Attach with the  $\frac{3}{4}$ ” diameter grade 5 nuts/bolts provided. Tighten bolts to  $\frac{1}{2}$  turn from snug tight or to 200 to 250 ft.-lbs. torque.
4. Locate **Cantilever Base** and stand the base on the end of the upright. Note that the flange with poll socket attached rests on the floor once column is standing. Attach with the  $\frac{3}{4}$ ” diameter grade 5 nuts/bolts provided. Tighten bolts to  $\frac{1}{2}$  turn from snug tight or to 200 to 250 ft.-lbs. torque.

5. Determine spacing and location of **Cantilever Arms**. Position the **Cantilever Arms** on the **Upright Column** at the desired heights and secure with four  $\frac{3}{4}$ " diameter, grade 5, nuts and bolts. Arms are always sloped up when mounted. Tighten bolts to  $\frac{1}{2}$  turn from snug tight or to 200 to 250 ft.-lbs. torque.
6. **USE EXTREME CAUTION AND FOLLOW SAFETY PROCEDURES IN STANDING THE UPRIGHT/BASE COMBINATIONS INTO A VERTICAL POSITION.** Using forklift with adequate height capacity, lift upright pair from top of upright, with forklift blades tilted back and under top horizontal brace. Using a spotter to note position of forklift blades and to ensure top of upright does not touch forklift mast or cage). Lift pair to a standing position. **SLOWLY** and **CAUTIOUSLY**

Once standing, lift upright pair and move into desired location, keeping forklift just behind upright. USE CAUTION! MOVE IN A SLOW, STEADY MOTION SO ALL EYES ARE ON UPRIGHT PAIR. VERIFY SAFETY PROCEDURES USED IN THIS PROCESS. On wall installations, use forklift extenders and sufficient dunnage to lift pair from the front and move into position.

7. Line up the front edge of the bases in the first cantilever unit to a predetermined mark or guide chalk line on the concrete foundation. Add additional cantilever units while maintaining the desired on-center spacing, e.g., 32" O.C., 42" O.C., 60" O.C. Cantilever units are braced on an "X-O-X" repeating pattern (in non-seismic areas). This means that the first and second upright columns will be attached to each other with a VB and an HB, as will the third and fourth; the second and third uprights may be attached to each other based on design requirements specified by NSF engineering. If no bracing (VB or HB) is used in alternating bays, the "on center" spacing must still be maintained as if they were separated by and attached to a brace. Alternating bay bracing may be added to maintain spacing. Seismic areas may require "X" braces in every bay. Should you have any questions regarding bracing requirements for your application, please consult your sales representative.
8. For double-sided cantilever rack, attach **Cantilever Base** on opposite side of column with the  $\frac{3}{4}$ " diameter grade 5 nuts/bolts provided, noting again that the flange with poll socket attaches on the floor side of the base. Tighten bolts to  $\frac{1}{2}$  turn from snug tight or to 200 to 250 ft.-lbs. torque.
9. For double-sided rack install arms on opposite side of column. It is sometimes helpful to install one lower level of arms along a run of cantilever first to support simple scaffolding of dimensional framing lumber to use as a working platform in order to install higher levels of arms. Determine spacing and location of **Cantilever Arms**. Position the **Cantilever Arms** on the **Upright Columns** at the desired heights and secure with four  $\frac{3}{4}$ " diameter, grade 5, nuts and bolts. Arms are always sloped up when mounted. Tighten bolts to  $\frac{1}{2}$  turn from snug tight or to 200 to 250 ft.-lbs. torque.
10. Make sure that all bases are lined up so that they toe the mark or chalk line. Slide on base laterally to the side just enough to locate the proper position for the hole to be drilled. Drill a  $\frac{5}{8}$ " (or  $\frac{3}{4}$ " diameter in the event  $\frac{3}{4}$ " anchors are used) hole into the concrete foundation with a hammer drill using the appropriate masonry bit. Drill to an appropriate depth for the anchor length. Insert the anchor and tighten to the recommended specifications of the manufacturer. Follow this procedure for the anchor pattern illustrated below, for either double or single-sided applications.

## CANTILEVER ANCHORING REQUIREMENTS

"⊕" INDICATES ANCHOR BOLT LOCATIONS



BASE / COLUMN ANCHORING DETAIL

SINGLE - SIDED

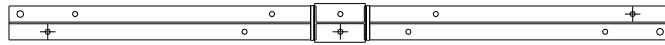

BASE / COLUMN ANCHORING DETAIL

DOUBLE - SIDED

STANDARD EXPANSION ANCHORS ARE EITHER 3/4" X 4-3/4"  
(LE = 3-1/8" MIN.) OR 3/4" X 5-1/2" (LE = 3-1/4" MIN.)  
ANCHORS IN THE DOUBLE-SIDED CANTILEVER MAY REQUIRE AN  
ADDITIONAL ANCHOR IN EACH BASE RATHER THAN THE COLUMN  
BASE PLATE.

11. Finish assembly with optional accessory items previously listed.