

LINESHAFT CONVEYOR STRAIGHT, CURVE AND SPUR

TECHNICAL HANDBOOK

Maintenance, Start Up and
Troubleshooting for Your
Omni Metalcraft Corp.
Equipment



DO NOT OPERATE
BEFORE READING

Omni Metalcraftcorp.

DO NOT DISCARD

TABLE OF CONTENTS

TABLE OF CONTENTS 2

GENERAL SAFETY STATEMENTS 3

-Introduction 3

-Cautions, Warnings and Hazards 3

SAFETY INFORMATION 4

-Safety Labels 4, 5

-Installation Safety 6

-Electrical Safety 7

-Operational Safety 8

-Maintenance and Service Safety 9, 10

-About Lineshaft Conveyors 11

-Lineshaft Safety Instructions 11

RECEIVING AND INSPECTION 12

-Returns, Damages and Shortages 12

-Removal of Crating 12

GENERAL INSTALLATION 13

-Overview 13

-Checking Unit Squareness 14

-Coupling / Attaching Bed Sections 15-17

LEG SUPPORTS AND INSTALLATION 18

-Permanent Installation of Legs 18

-Leg Adjustments 18

KNEE BRACES, CASTERS AND CEILING HANGERS 19

-Installing Knee Braces and Casters 19

-Installing Ceiling Hangers 20

MULTI-TIER SUPPORTS 21

-Installation of Multi-Tier Supports 21

PRE-START-UP OVERVIEW 22

-Preparing for Initial Start-Up 22

-Drive Chain and Sprocket Alignment 23

-Drive Chain and Sprocket Tension 24

-Gear Reducer Vent Plug 24

MAINTENANCE 25

-Inspection and Lubrication 25

-Maintenance Schedules 26

-Report on Miscellaneous Maintenance Performed 27

TROUBLESHOOTING AND REPLACEMENT PARTS 28

-Troubleshooting 28, 29

PARTS LISTS 30

-Lineshaft Straight 30

-Lineshaft Curve 31

-Lineshaft Curve - Tangent 32

-Lineshaft Spur 33, 34

NOTES 35

WARRANTY 36

GENERAL SAFETY STATEMENTS

**IMPORTANT
REQUIRED READING!**



**¡IMPORTANTE!
¡LECTURA OBLIGATORIA!**

To ensure this quality product is safely and correctly utilized, all instructions within this manual must be read and understood prior to equipment start-up. Be aware of all safety labels on machinery. **If you do not understand any of the safety instructions or feel there may be safety labels missing, contact your supervisor or product supplier immediately!**

Para garantizar que este producto de calidad se utilice correctamente y con seguridad, es necesario leer y comprender las instrucciones incluidas en este manual, antes de comenzar a utilizar el equipo. Esté atento a todas las etiquetas de seguridad que se encuentran en las máquinas. Si no entiende alguna de las instrucciones de seguridad o considera que faltan algunas etiquetas de seguridad, ¡comuníquese inmediatamente con su supervisor o proveedor del producto!

COMPLIANCE WITH SAFETY STANDARDS

Compliance with safety standards, including federal, state and local codes or regulations is the responsibility of the conveyor purchaser(s). Placement of guards, safety labels and other safety equipment is dependent upon the area and use to which the system is applied. A safety study should be made of the conveyor application by the purchaser(s). It is the purchaser's responsibility to provide any additional guards, safety labels or other safety equipment deemed necessary based on this safety study.

The information contained in this safety manual is correct at the time of printing. Due to the continuing development of product lines, changes in specifications are inevitable. The company reserves the right to implement such changes without prior notice.



If you suspect fire hazards, safety hazards, dangers towards health or any other job safety concerns, consult your federal, state or local codes.



Certain safety information in this document was reprinted from ASME B20.1-2000 by permission of The American Society of Mechanical Engineers. All rights reserved.
Inspect equipment for **safety labels**. Make sure personnel are aware of and follow safety instructions.



Maintain an **orderly environment** in the vicinity of the conveyor at all times. Clean up spilled materials or lubricants immediately.



All personnel shall be instructed regarding the necessity for continuous care and attention to safety during the operation of a conveyor. They **must be trained** to identify and immediately report all unsafe conditions or practices relating to the conveyor and its operation.



Know your company's machine specific **Lockout / Tagout procedure**. **Do Not** perform maintenance until electrical disconnect has been turned off!



Replace all safety devices, guards and guarding prior to equipment start-up.

References used for safety instructions in this manual are from: Conveyor Equipment Manufacturers Association (CEMA) and The American Society of Mechanical Engineers (ASME)

SAFETY INFORMATION: SAFETY LABELS

Safety labels have been placed at various points on the equipment to alert everyone of potential dangers. Inspect equipment for proper position of safety labels and make sure all personnel are aware of the labels and obey their warnings. As mentioned in the previous section, a safety study should be made of the conveyor application by the purchaser(s). **It is the purchaser's responsibility to provide any additional guards, safety labels or other safety equipment deemed necessary based on this safety study.** The following pages contain typical safety labels that may have been attached to your equipment.

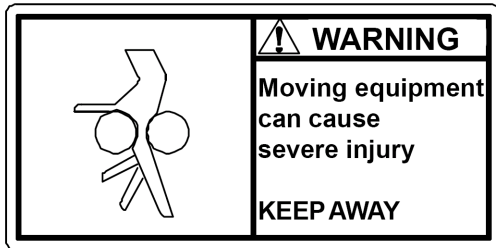

#110479 (5" x 2 1/2")
Placed on terminating ends (both ends) where there are exposed moving parts which must be unguarded to facilitate function, i.e. rollers, pulleys, shafts, chains, etc.

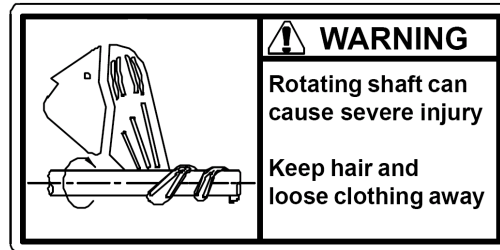

#113529 (5" X 2 1/2")
Placed next to drive (both sides) to warn personnel that the lineshaft conveyor utilizes a rotating shaft which may be hazardous if hair or loose clothing become entangled around the rotating shaft. Also used on any other conveyors where the exposed shaft may create similar hazards.

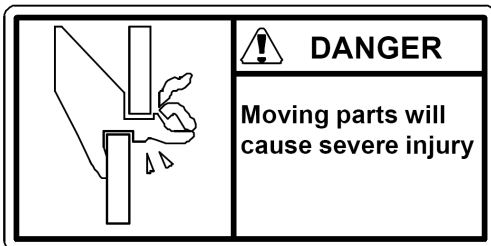

#111744 (5" X 2 1/2")
General warning to personnel that the equipment's moving parts, which operate unguarded by necessity or function, i.e., air cylinders, etc., create hazards to be avoided.

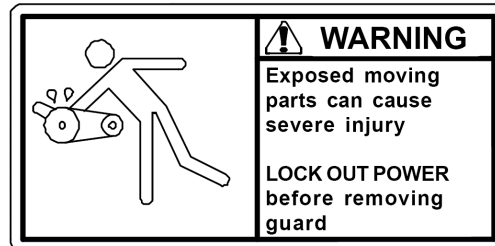

#110478 (5" X 2 1/2")
Placed on all chain guards to warn that operation of the machinery with guards removed would expose chains, belts, gears, shafts, pulleys, couplings, etc. which create hazards.

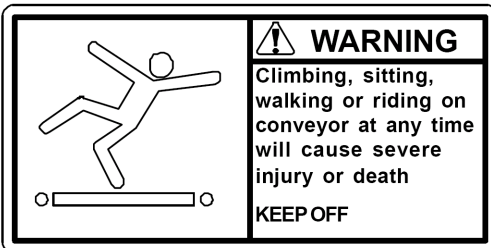

#111752 (5" X 2 1/2")
Placed on max. of 20' centers (both sides) along conveyors which provide surfaces and profiles attractive, but hazardous, for climbing, sitting, walking or riding.



#113513 (5" X 2 1/2")
Placed on chain guard base so label is visible when guard cover is removed.

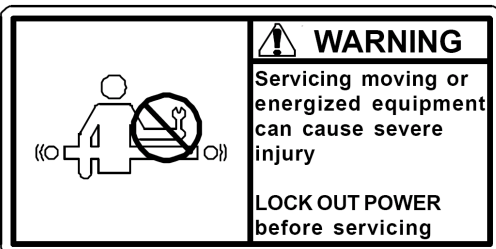

#113528 (5" X 2 1/2")
Placed next to drive (both sides) to warn maintenance personnel that conveyors must be shut off and locked out prior to servicing. Examples: drives, take-ups, and lubrication points, which require guard removal.



#111870 (5" X 3")
General warning of pinch point hazards.

SAFETY INFORMATION: SAFETY LABELS (Continued)

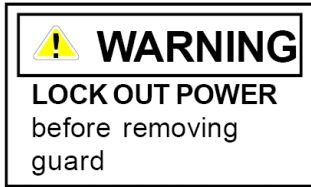

#111750 (1 3/4" x 1 1/4")
Generally placed on smaller guards to alert personnel of potential danger if guard is removed and power is not locked out.



#111749 (3" x 1 1/4")
Placed on shipping brace which stabilizes equipment during shipping. Brace must be removed before operating! May cause severe injury if not removed.



#110491 (10" x 7")
Placed on equipment where conveyors may start without warning.

SAFETY INFORMATION: INSTALLATION SAFETY

1) **LOADING / UNLOADING**

Have trained personnel load or unload equipment. The conveyor must be properly handled when transferring from the unloading area to final site location to prevent damage.

2) **GUARDS / GUARDING**

Interfacing of Equipment. When two or more pieces of equipment are interfaced, special attention shall be given to the interfaced area to ensure the presence of adequate guarding and safety devices.

Guarding Exceptions. Wherever conditions prevail that would require guarding under this standard but such guarding would render the conveyor unusable, seek guidance from your safety professional.



3) **ANCHORING**

DO NOT operate conveyor unless it is properly anchored. Serious injury or death may result.

4) **SAFETY WARNING**

Install all safety devices, guards and guarding prior to equipment start-up.

SAFETY INFORMATION: ELECTRICAL SAFETY

1) ELECTRICAL CODE

All electrical installations and wiring shall conform to federal, state and local codes.

When conveyor operation is not required for a maintenance procedure, **electrical power must be turned off and locked / tagged out following your company's machine specific procedure.**

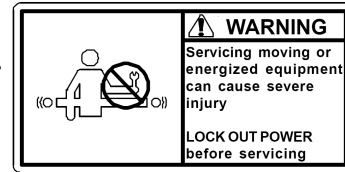

2) CONTROL STATION

Control stations should be so arranged and located that the operation of the affected equipment is visible from them. Control stations shall be clearly marked or labeled to indicate the function controlled.

A conveyor that would cause injury when started shall not be started until personnel in the area are alerted by a signal or by a designated person that the conveyor is about to start.

Where system function would be seriously hindered or adversely affected by the required time delay, or where the intent of the warning may be misinterpreted (i.e., a work area with many different conveyors and allied devices), a clear, concise and legible warning sign needs to be provided. The warning sign shall indicate that conveyors and allied equipment may be started at any time, that danger exists and that personnel must keep clear. These warning signs shall be provided along the conveyor at areas not guarded by position or location.

Remotely and automatically controlled conveyors, and conveyors where operator stations are not manned or are beyond voice or visual contact from drive areas, loading areas, transfer points and other potentially hazardous locations on the conveyor path not guarded by location, position or guards shall be furnished with emergency stop buttons, pull cords, limit switches or similar emergency stop devices.

All such emergency stop devices shall be easily identifiable in the immediate vicinity of such locations unless guarded by location, position or guards. Where the design, function and operation of such conveyor clearly is not hazardous to personnel, an emergency stop device is not required.

The emergency stop device shall act directly on the control of the conveyor concerned and shall not depend on the stopping of any other equipment. The emergency stop devices shall be installed so that they cannot be overridden from other locations.

Inactive and unused actuators, controllers and wiring should be removed from control stations and panel board, together with obsolete diagrams, indicators, control labels and other material that might confuse the operator.

3) SAFETY DEVICES

All safety devices, including wiring of electrical safety devices, shall be arranged to operate such that a power failure or failure of the device itself will not result in a hazardous condition.

4) EMERGENCY STOPS AND RESTARTS

Conveyor controls shall be so arranged that, in case of emergency stop, manual reset or start at the location where the emergency stop was initiated shall be required for the conveyor(s) and associated equipment to resume operation.

Before restarting a conveyor that has been stopped because of an emergency, an inspection of the conveyor shall be made and the cause of the stoppage determined. The starting device and electrical power must be turned off and locked / tagged out according to your company's machine specific procedure before any attempt is made to remove the cause of the stoppage, unless operation is necessary to determine the cause or to safely remove the stoppage.

5) SAFETY WARNING

Replace all safety devices, guards and guarding prior to equipment start-up.

SAFETY INFORMATION: OPERATIONAL SAFETY

Only trained, qualified personnel shall be permitted to operate a conveyor. Training shall include instruction in operation under normal conditions and emergency situations.

Where safety is dependent upon stopping / starting devices, they shall be kept free of obstructions to permit access.

The area around loading and unloading points shall be kept clear of obstructions that could endanger personnel.

Do not ride the load-carrying element of a conveyor under any circumstances, unless the conveyor is designed and equipped with safety and control devices intended to carry personnel. For no reason shall a person ride any element of a vertical conveyor. Warning labels reading **“DO NOT RIDE CONVEYOR”** shall be affixed by the owner of the conveyor.



Personnel working on or near a conveyor shall be instructed as to the location and operation of pertinent stopping devices.

A conveyor shall be used to transport only a load that it is designed to handle safely.

Under no circumstances shall the safety characteristics of the conveyor be altered.

Routine inspections and preventative and corrective maintenance programs shall be conducted to ensure that all safety features and guards are retained and function properly. Inspect equipment for safety labels. Make sure personnel are aware of and follow safety label instructions.

Alert all personnel to the potential hazard of entanglement in conveyors caused by items such as long hair, loose clothing and jewelry.

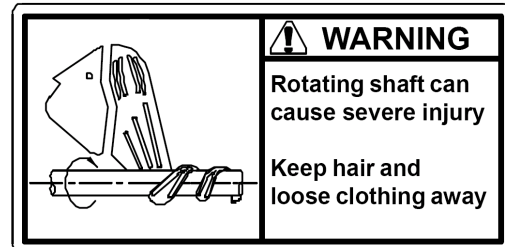

SAFETY WARNING

Replace all safety devices, guards and guarding prior to equipment start-up.

SAFETY INFORMATION: MAINTENANCE / SERVICE SAFETY

ELECTRICAL POWER MUST BE TURNED OFF AND LOCKED / TAGGED OUT following your company's machine specific procedures when servicing conveyor to prevent accidental restarting by other persons or interconnecting equipment (when used).

1) MAINTENANCE (REPAIR)

Maintenance and service shall be performed by trained, qualified personnel only.

Where lack of maintenance and service would cause a hazardous condition, the user shall establish a maintenance program to ensure that conveyor components are maintained in a condition that does not constitute a hazard to personnel.

No maintenance or service shall be performed when a conveyor is in operation. See "Lubrication" and "Adjustment or Maintenance During Operation" for exceptions.

When a conveyor is stopped for maintenance or service, the starting devices, prime mover, powered accessories or electrical must be locked / tagged out in accordance with a formalized procedure designed to protect all persons or groups involved with the conveyor against an unexpected restart. Personnel should be alerted to the hazard of stored energy, which may exist after the power source is locked out. All safety devices and guards shall be replaced before starting equipment for normal operation.

2) ADJUSTMENT OR MAINTENANCE DURING OPERATION

When adjustments or maintenance must be done while equipment is in operation, only trained, qualified personnel who are aware of the hazards of the conveyor in motion shall be allowed to make adjustments, perform maintenance or service.

Conveyors shall NOT be maintained or serviced while in operation unless proper maintenance or service requires the conveyor to be in motion. If conveyor operation is required, personnel shall be made aware of the hazards and how the task may be safely accomplished.

3) LUBRICATION

Conveyors shall **NOT** be lubricated while in operation unless it is impractical to shut them down for lubrication. Only trained and qualified personnel who are aware of the hazards of the conveyor in motion shall be allowed to lubricate a conveyor that is operating.

Where the drip of lubricants or process liquids on the floor constitutes a hazard, drip pans or other means of eliminating the hazard must be provided by purchaser(s).

4) MAINTENANCE OF GUARDS AND SAFETY DEVICES

Guards and safety devices shall be maintained in a serviceable and operational condition. Warning signs are the responsibility of the owner of the conveyor and must be maintained in a legible / operational condition.



5) **INSPECTIONS**

Routine inspections with preventative and /or corrective maintenance programs shall be conducted to ensure that all safety features and devices are maintained and function properly.

All personnel shall inspect for hazardous conditions at all times. Remove sharp edges or protruding objects. Repair or replace worn or damaged parts immediately.

6) **CLEANING**

Where light cleaning and/or casing cleaning are required, they shall be performed by trained personnel. The conveyor electrical power **must be turned off and locked / tagged out following your company's machine specific procedures**. Special attention may be required at feed and discharge points.

7) **SAFETY WARNING**

Replace all safety devices, guards and guarding prior to equipment start-up.

SAFETY INFORMATION: ABOUT LINESHAFT

DEFINITION

Lineshaft driven live roller conveyors are a unique concept in powered conveyors. The basic design employs rollers which are independently driven by a urethane drive belt from a common drive shaft.

The general operation of the conveyor is a drive shaft that spans the full length of the conveyor and transmits power to the rollers via a drive spool and belt. When back pressure is applied to the conveyed product, the spools driving the rollers under the product will slip on the drive shaft allowing the product to accumulate with a minimum amount of back pressure.

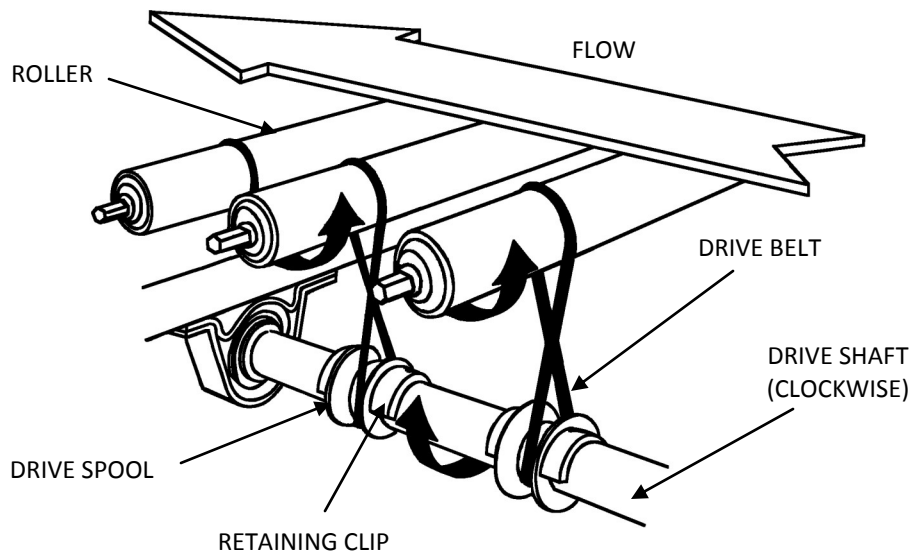

SAFETY INFORMATION: LINESHAFT SAFETY INSTRUCTIONS

LINESHAFT SAFETY INSTRUCTIONS

Lineshaft conveyor is a powered conveyor that can only be stopped by cutting power to its motor. Lineshaft conveyor contains many parts including sprockets, spools, shafts, chains, belts and rollers. Any moving part is a potential source of danger; especially to careless or untrained personnel. Although guards are provided to prevent contact with the conveyor's components, all personnel should be instructed in the necessity for continuous care and attention to safety in the operation of a conveyor.

PARTICULAR DANGER AND PINCH POINTS

- 1) Any point at which a belt bends around a roller or pulley.
- 2) Any point where two rollers or pulleys are close together and produce a "wringer" effect.
- 3) Any point where accessories are located that also have moving parts.

RECEIVING AND INSPECTION: RETURNS, DAMAGES AND SHORTAGES

UNCRATING CHECKLIST

- 1) Compare the bill of lading with what you have received (including accessories).
- 2) Examine the equipment for damage.
- 3) Immediately report shortage or damages to the vendor and carrier.
- 4) Obtain a signed damage report from the carrier and send a copy to the vendor.

Do not attempt to modify or repair damaged equipment without authorization from vendor.

Note:

Do not return equipment to the factory without a written return authorization. Returns without written authorization will not be accepted.

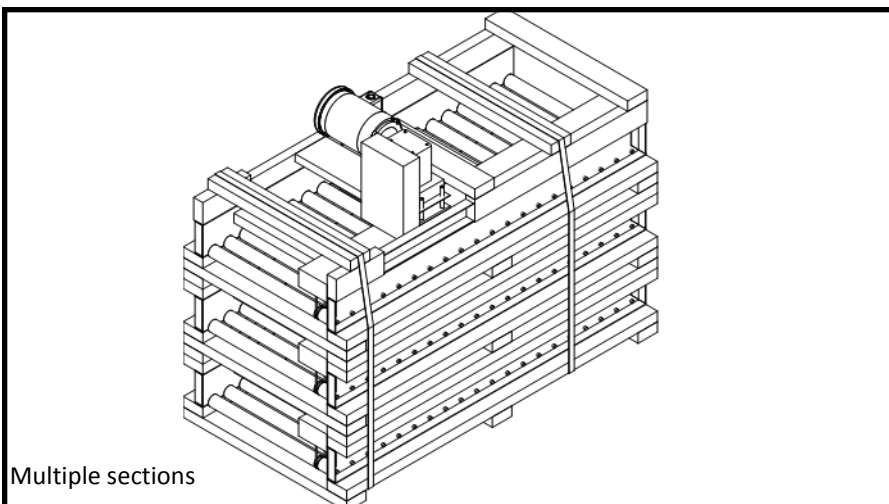
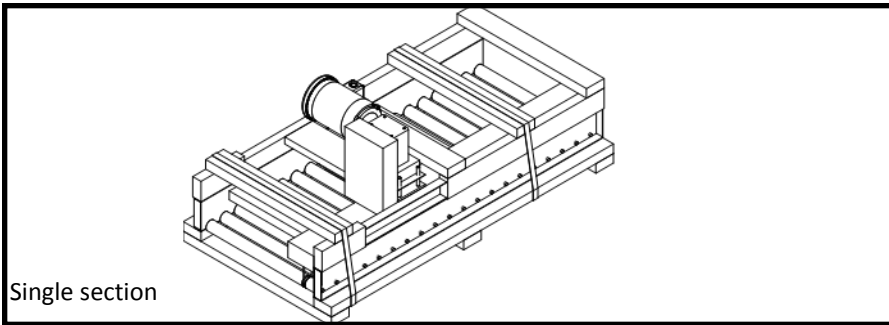

Note: Custom products may be crated differently to fit the conveyor design.

RECEIVING AND INSPECTION: REMOVAL OF CRATING

AFTER COMPLETING THE "UNCRATING CHECKLIST"

- 1) Remove crating and packaging.
- 2) Look for boxes, accessories, bags or components such as fasteners, manuals, guard rails etc. that may be banded or fastened to the crating material.

Note: Make sure all fasteners, guards and essential components are not discarded.

GENERAL INSTALLATION: OVERVIEW

- 1) Wherever it is possible, installation should begin at one end of a system and continued through until it is complete. This note holds true for both the leveling procedure and the shaft alignment procedure.
- 2) If any obstructions are present that were overlooked in the system layout, the conveyor may have to be rerouted. If this situation occurs, consider beginning installation at the rerouting point and continue in either direction as necessary.
- 3) When the lineshaft conveyor system is to travel between different rooms or departments, particular attention must be paid to floor levels in order to achieve proper installation.
- 4) Never begin installation at opposite ends of a system and work toward the center. Shaft alignment problems are highly likely to occur in this case.

GENERAL INSTALLATION: CHECKING UNIT SQUARENESS

SQUARING

Frame squareness can be checked by using a simple right angle square as shown or by measuring from the same points diagonally, corner to corner.

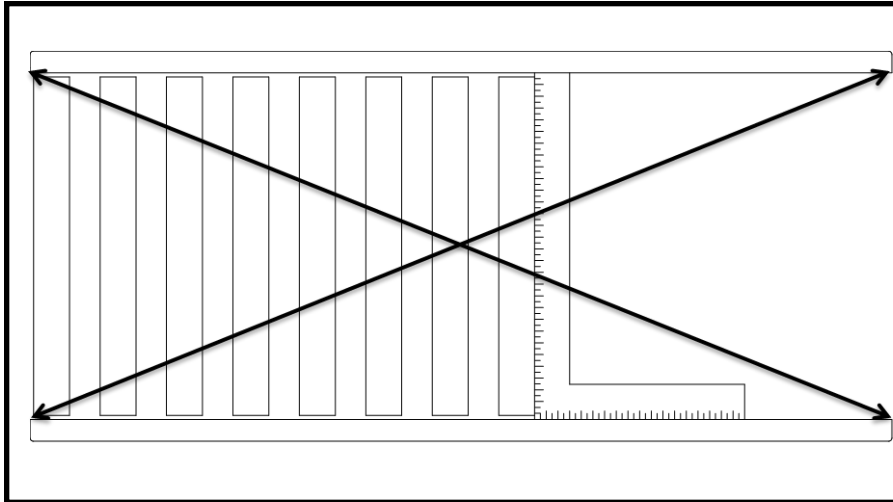

Note:

Make sure frames are square (as shown) or products will skew and tumble from the conveyor. Failure to square frames may also cause premature conveyor wear and failure.

GENERAL INSTALLATION: COUPLING / ATTACHING BED SECTIONS

FRAME COUPLING

With the Delrin Chain Coupler removed, couple the frame sections using the supplied fasteners as shown in the drawing below.

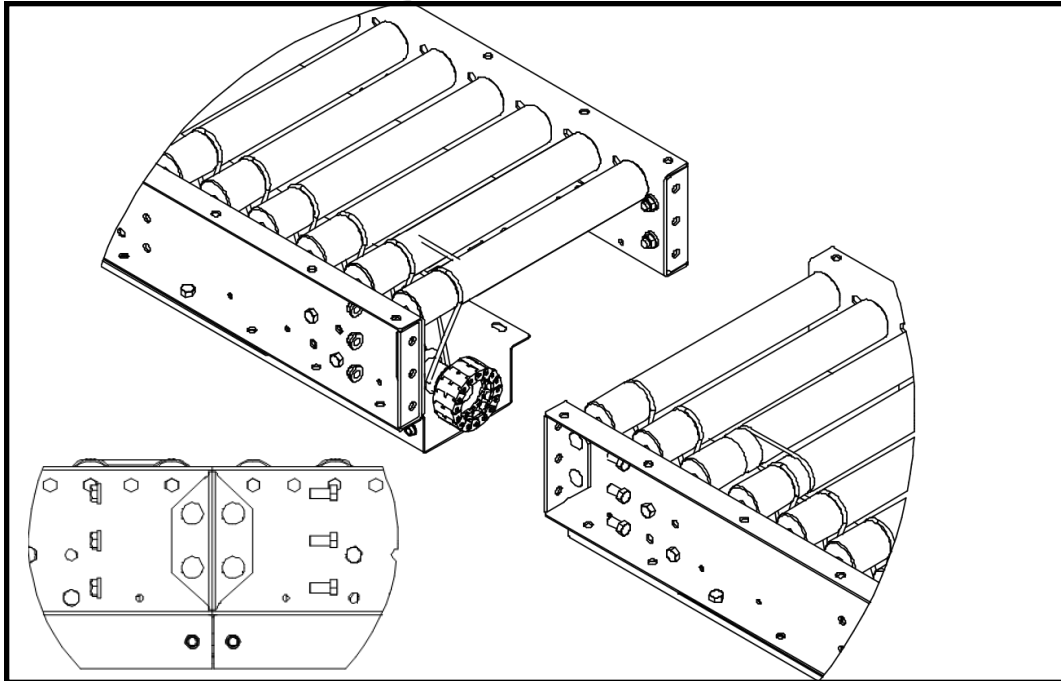

Note:

For ease of installation, mount legs on each conveyor section prior to coupling.

DELRIN COUPLINGS

- 1) Starting at one end of the drive section, begin the assembly of Delrin couplers at each joint.
 - A) Remove two rollers each side of joint.
 - B) Remove snap-on plastic clips from the shaft in the area between the shaft support bearings.

REMOVE (2) ROLLERS EACH SIDE OF JOINT

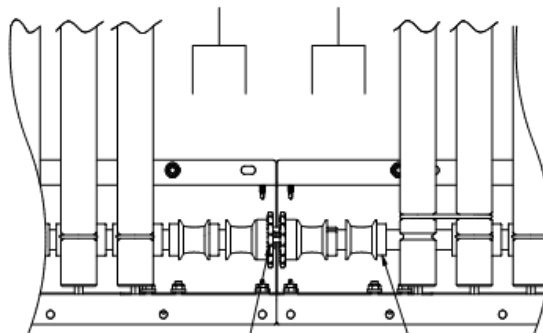

SLIDE BACK THE SPROCKET (BOTH SIDES)

REMOVE PLASTIC SNAP-ON CLIPS (BOTH SIDES)

- C) Remove the belts that retain the Delrin couplers and remove the tape from the end of the shaft.
- D) Slide the sprocket further apart, exposing both ends of the shaft.

GENERAL INSTALLATION: COUPLING / ATTACHING BED SECTIONS

- E) Using 1/4 inch keystock, check the shaft alignment at 90 degree intervals and adjust for horizontal or vertical misalignment if necessary.

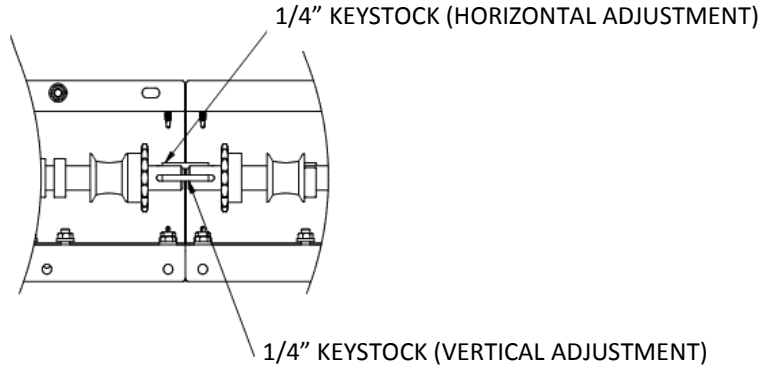

HORIZONTAL ADJUSTMENT

Loosen two bearings each side of joint where they attach to the spreaders. Align the shaft and re-tighten the bearings. Verify alignment.

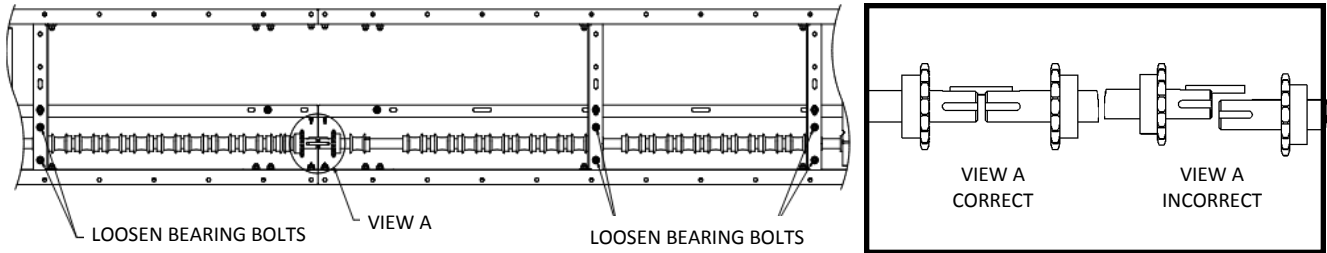

VERTICAL ADJUSTMENT

Loosen two spreaders each side of joint on the shaft side where they attach to the side frames. Align the shaft and the spreaders. Verify alignment and re-tighten.

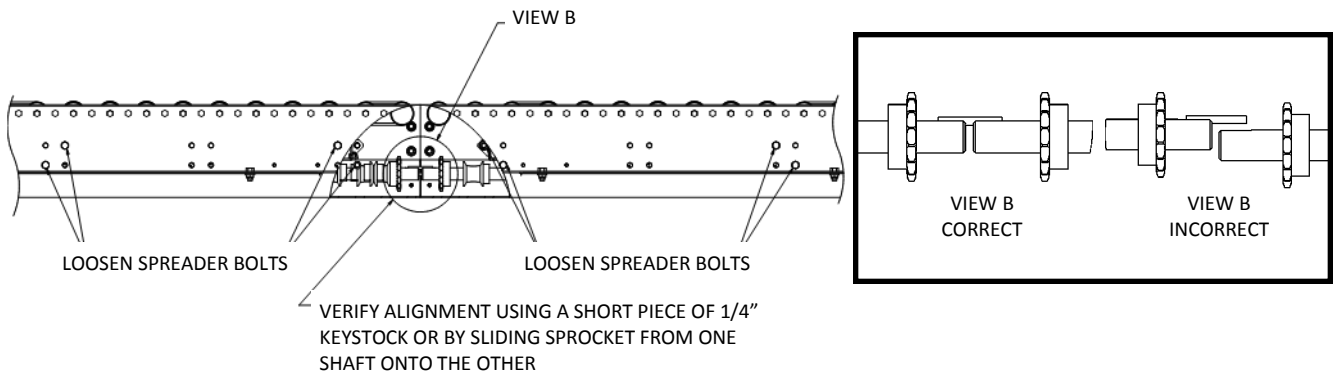

- F) Tighten one sprocket flush with the end of the shaft. Make sure both set screws are tightened securely.

GENERAL INSTALLATION: COUPLING / ATTACHING BED SECTIONS

- G) Move the other sprocket to the end of the shaft. The 1/4 inch keystone should pass between the sprocket faces to establish the distance apart. Tighten the other sprocket. Make sure both set screws are tightened securely.
- H) Replace the plastic snap-on clips. Wrap Delrin coupling around the sprockets to make sure it fits EASILY over the teeth. If it does not fit easily, see step 1D. **DO NOT ASSEMBLE DELRIN CHAIN AT THIS TIME.** It will be easier to line up the shafts on future joints if the shaft can turn freely.

NOTE: When properly assembled, arrangement should look like this:

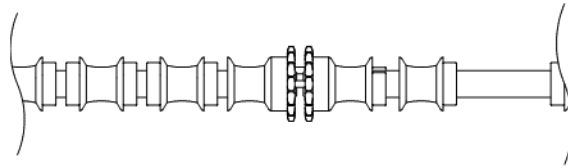

- 2) Repeat Step 1 at every joint.
- 3) For Curves
 - A) Repeat Step 1 except primary adjustments should be made in the curve and not in the straight section because there is a greater chance of misalignment due to manufacturing tolerances between a curve and a straight than between two straight sections.
 - B) Align and reconnect after all other connections are made.
- 4) Assemble Delrin chain over the sprockets at every joint. The pin should be pushed in with channel locks (see sketch). **DO NOT HAMMER PIN INTO PLACE.** This will damage the Delrin coupling.
- 5) Reassemble the rollers at each joint from Step 1A.
- 6) Two spool guard end caps and two shaft collars are supplied with every drive section. At the end of the last slaved section, remove the sprocket and key. Bolt in the spool guard end cap.

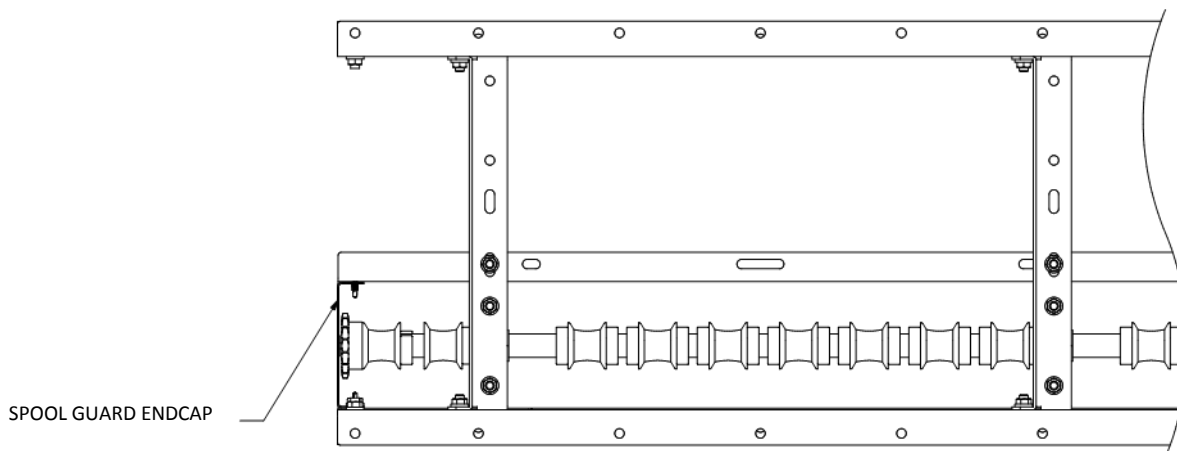
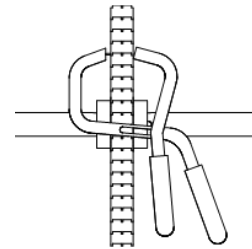

SAFETY WARNING:

Replace all safety devices, guards and guarding prior to equipment start-up.

LEG SUPPORTS AND INSTALLATION

PERMANENT INSTALLATION OF LEGS

Secure leg supports to the floor utilizing the lag holes in the adjustable leg boot.

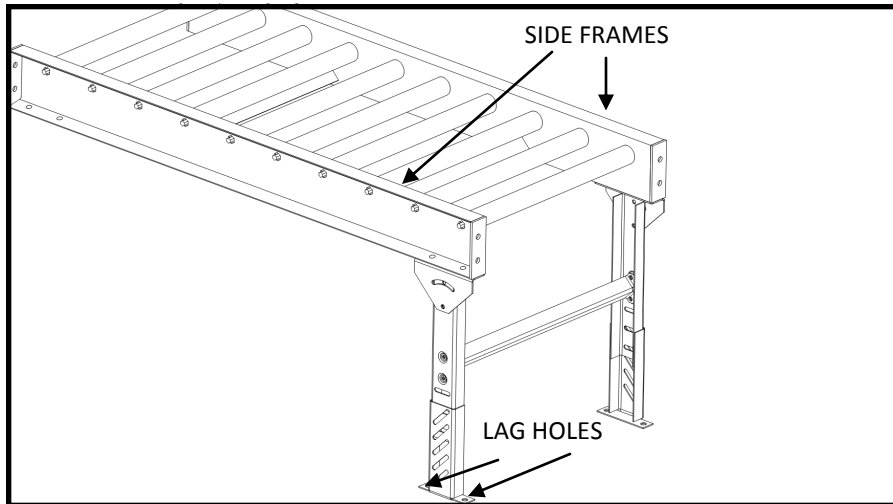

Note:

Make sure the conveyor is level by placing a level on the conveyor side frames. If the conveyor is not level, adjust the legs appropriately as shown below.

LEG ADJUSTMENT: BOLT-TOGETHER LEGS

- 1) The conveyor electrical power must be turned off and locked / tagged out following your company's machine specific procedures.
- 2) Remove all load from the conveyor.
- 3) Position conveyor in the location to be installed.
- 4) Support conveyor section with jack, hoist or forklift.
- 5) Carefully loosen the fasteners within the slots.
- 6) Lift or lower conveyor until it is at the desired height.
- 7) Ensure that the conveyor is completely level. (reference leveling note below)
- 8) Tighten fasteners using torque appropriate for each fastener's size and grade. (grade 5 fasteners provided)

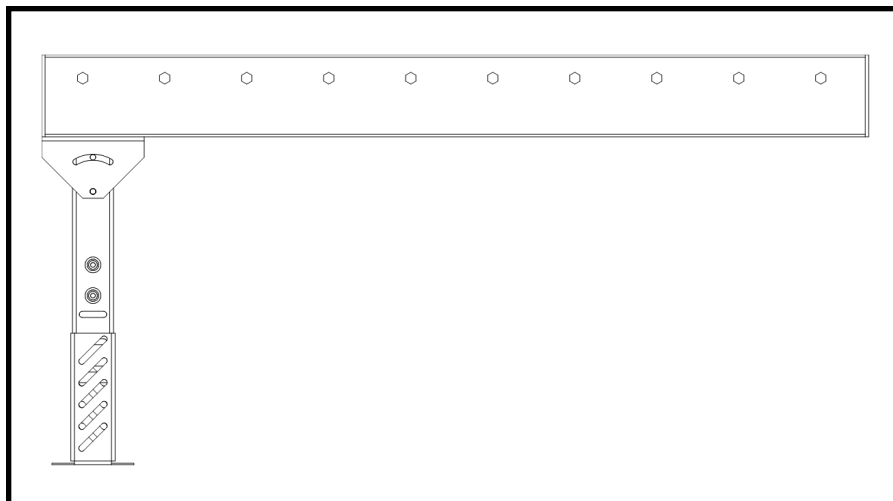
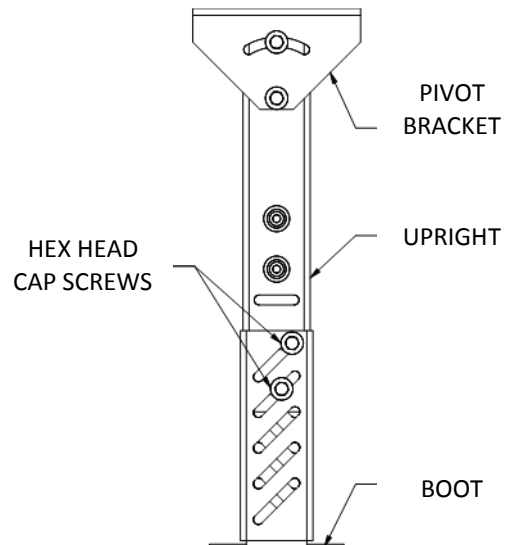

Note:

Only qualified installation professionals should level and install conveyor.

KNEE BRACES, CASTERS AND CEILING HANGERS: INSTALLING KNEE BRACES

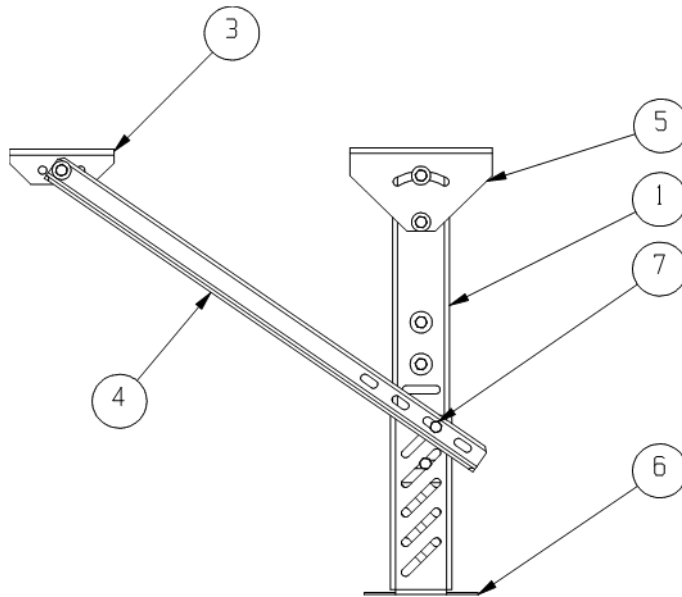

INSTALLING KNEE BRACES

- 1) After leg supports are set in place, attach the brace bracket.
- 2) Attach knee brace angle to the leg support and brace bracket.

(Knee brace angle may need to be cut, drilled and trimmed for proper fit and to eliminate interference with adjacent equipment)

Note:

Knee braces are recommended when the conveyor height exceeds 36" and/or when additional stability is needed.

DETAIL	DESCRIPTION
1	UPRIGHT
2	SPREADER
3	BRACE BRACKET
4	KNEE BRACE ANGLE
5	PIVOT BRACKET
6	FOOT
7	HEX HEAD CAP SCREW

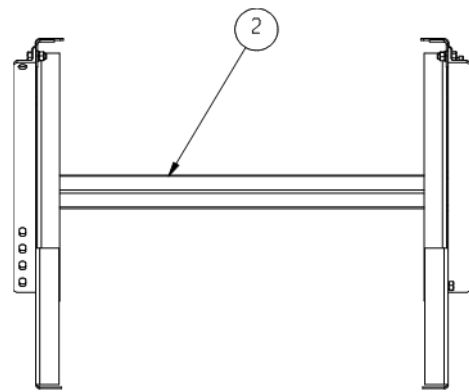

KNEE BRACES, CASTERS AND CEILING HANGERS: INSTALLING CASTERS

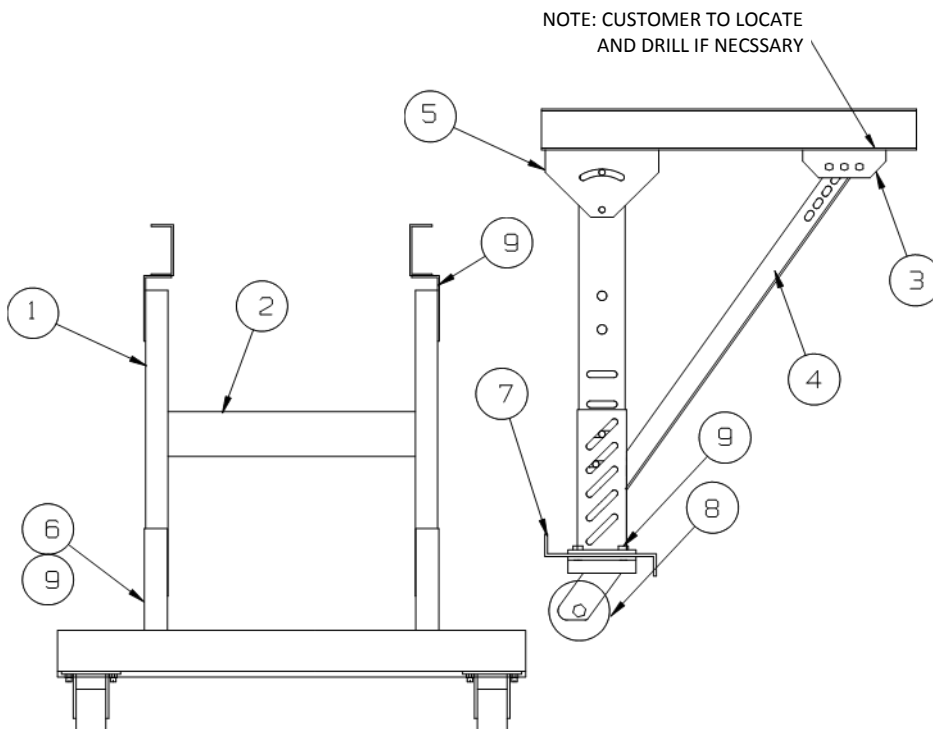

INSTALLING CASTERS

Once in position, casters should be locked until conveyor needs to be moved again.

Note:

Leg supports with casters follow similar installation instructions as standard leg supports and knee braces.

DETAIL	DESCRIPTION
1	UPRIGHT
2	SPREADER
3	BRACE BRACKET
4	KNEE BRACE ANGLE
5	PIVOT BRACKET
6	FOOT
7	Z-PLATE
8	PHENOLIC CASTER
9	HEX HEAD CAP SCREW

KNEE BRACES, CASTERS AND CEILING HANGERS: INSTALLING CEILING HANGERS

INSTALLING CEILING HANGERS

When using conveyors in an overhead scenario, mount hangers at section joints.

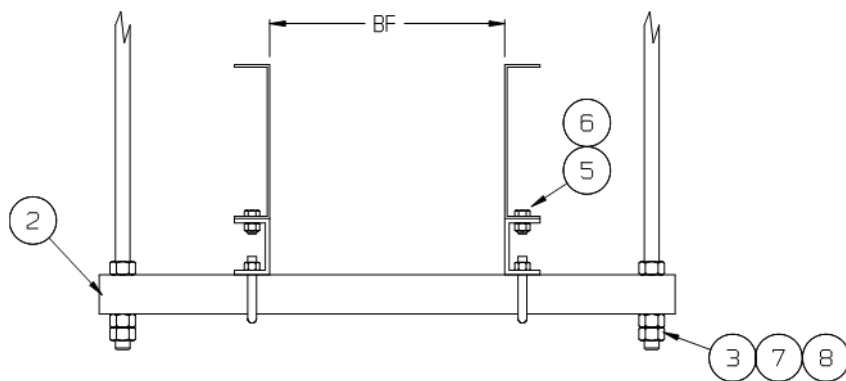

Note:

When installing ceiling hangers, refer to local building codes to ensure that materials comply. Only experienced material handling installers should attempt to install conveyors.

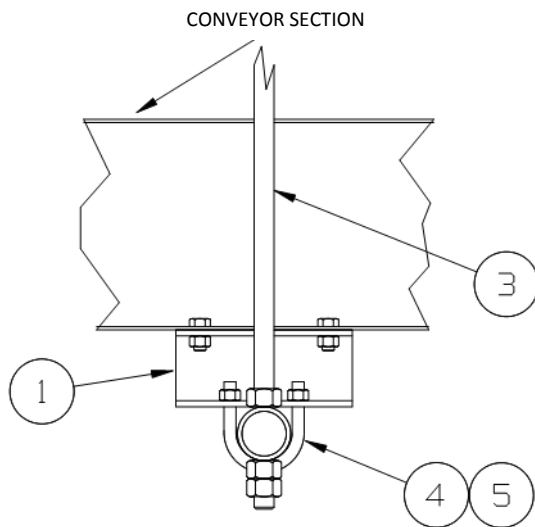

DETAIL	DESCRIPTION
1	HANGER CHANNEL
2	PIPE SPREADER
3	THREADED ROD
4	U-BOLT
5	WHIZ NUT
6	HEX HEAD CAP SCREW
7	HEX NUT
8	LOCK WASHER

MULTI-TIER SUPPORTS: INSTALLATION OF MULTI-TIER SUPPORTS

INSTALLING MULTI-TIER SUPPORTS

- 1) Remove the upper spreader (detail 2) from support.
- 2) Lower the conveyor section onto the lower spreader (detail 2) and attach using supplied fasteners.
- 3) Check for appropriate elevation and attach the knee bracket assembly (detail 3,4,6,7,8).
- 4) For upper conveyor assembly, replace upper spreader and repeat steps 2 and 3.
- 5) Make sure all multi-tier supports are in line and square prior to conveyor start-up.

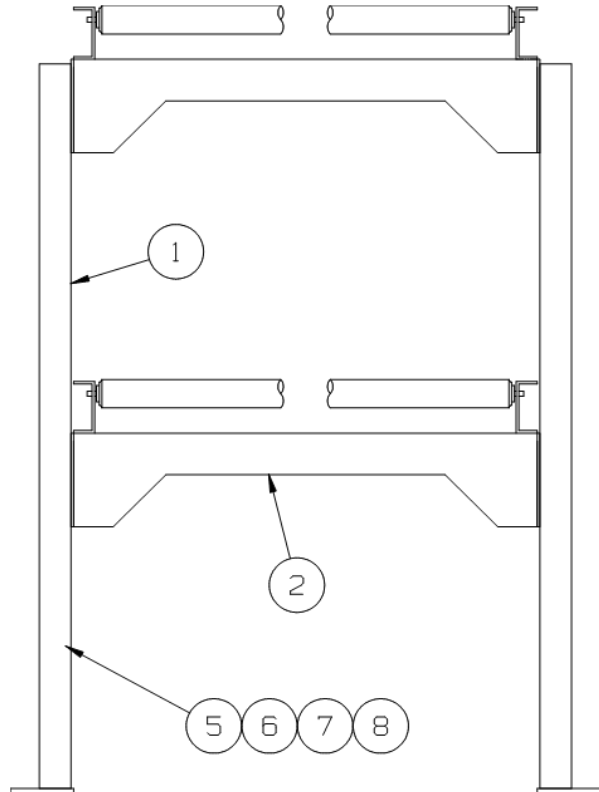
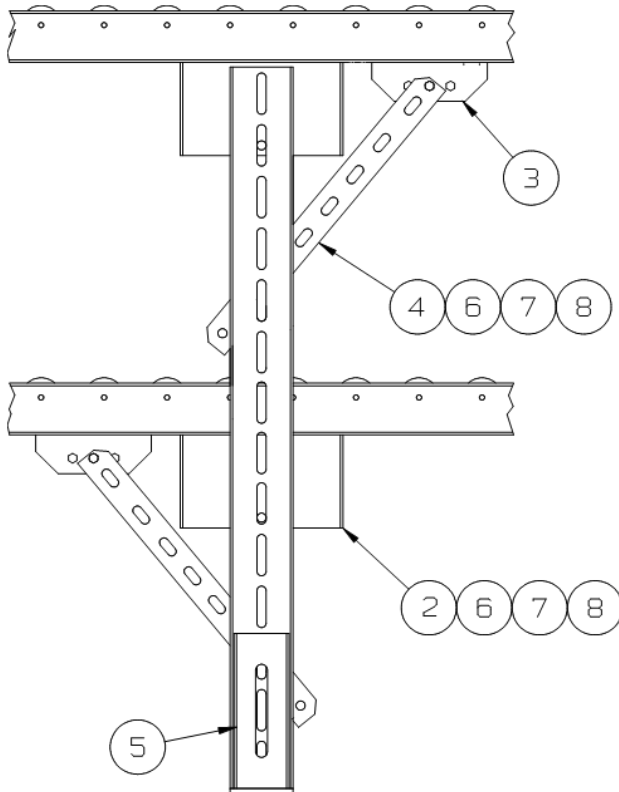

Note: Make sure that the conveyor is stable prior to multi-tier assembly. Use of a forklift or crane may be required to ensure safe handling. Only experienced installation professionals should install conveyor.

DETAIL	DESCRIPTION
1	UPRIGHT
2	SPREADER
3	BRACE BRACKET
4	KNEE BRACE ANGLE
5	FOOT WELDMENT
6	WHIZ NUT
7	HEX HEAD CAP SCREW
8	FLAT WASHER

PRE-START-UP OVERVIEW: PREPARING FOR INITIAL START-UP

- 1) Review pages 7 through 10 prior to starting any equipment.
- 2) Verify that conveyor sections, leg supports, etc. were installed properly.
- 3) Verify that drive chains and sprockets are installed, aligned and tensioned properly
- 4) Verify set screws are tight in sprockets, bearings and all components that have them in.
- 5) Verify that all drive and mounted bearing bolts are fastened securely.
- 6) Verify that all motor control wiring is connected properly.
- 7) Verify that conveyor is not loaded with product.
- 8) Verify that gearboxes are filled with the proper amount of oil or that they were factory filled with lube. (If your conveyor is equipped with a Boston 700 Series Reducer, it is filled with oil, sealed and lubed for life thus requiring no oil changes. Literature provided with equipment will give detailed info on gearbox lube info)
- 9) Verify that the gearbox has necessary vent plugs installed if applicable. (If your conveyor is equipped with a Boston 700 Series Reducer, it is supplied with a PosiVent® and no vent plug is required. Literature provided with equipment will give detailed info on gearbox vent plug requirements.)

PRE-START-UP OVERVIEW: DRIVE CHAIN AND SPROCKET ALIGNMENT

DRIVE CHAIN AND SPROCKET ALIGNMENT

To achieve maximum service life and efficiency from a chain drive, follow these simple guidelines:

- Visually inspect the roller chain, sprockets, and other components and verify that they are in good condition.
- Ensure that the sprockets are properly aligned.
- Adequately lubricate the chain.
- Inspect for proper chain tension.

CONDITION OF COMPONENTS

Shafting and bearings should be supported rigidly to maintain the initial alignment.

Roller chain should be free of grit and dirt. Wash chain in kerosene when required. Relubricate.

DRIVE ALIGNMENT

Misalignment results in uneven loading across the width of the chain and may cause roller link-plate and sprocket tooth wear. Drive alignment involves two things: parallel shaft alignment and axial sprocket alignment.

ALIGNING SHAFTS

Shafts should be parallel and level. If there is axial movement of the shaft (as in the case of an electric motor), lock the shaft in the normal running position before aligning the sprockets.

ALIGNING SPROCKETS

Sprocket axial alignment can be checked with a straight edge which will extend across the finished sides of the two sprockets. Normally, it is good practice to align the sprockets as close to the shaft bearing as possible. For long center distances, use a taut cord, or wire long enough to extend beyond each of the sprockets.

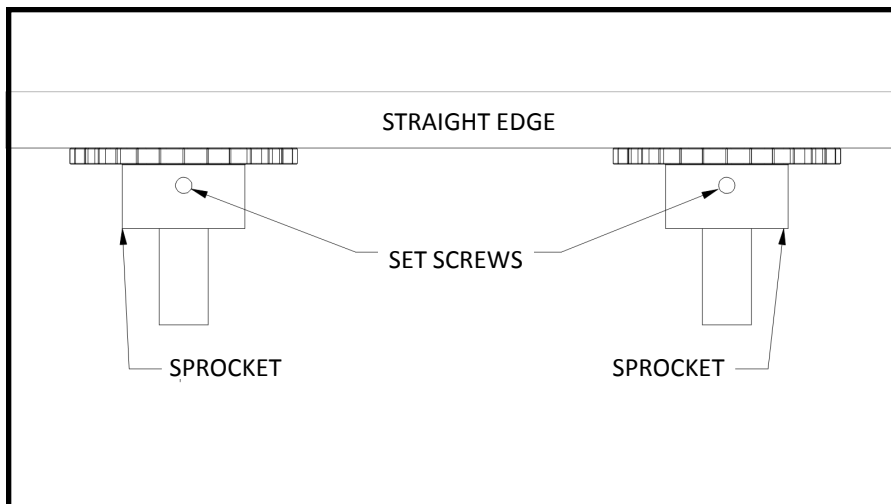

WARNING:

Before performing any maintenance, lubrication or inspection on any powered conveyor, the electrical power must be turned off and locked / tagged out following your company's machine specific procedure. **NEVER** operate the conveyor with any guard removed.

PRE-START-UP OVERVIEW: DRIVE CHAIN AND SPROCKET TENSION

INSTALLING THE CHAIN

Recheck all preceding adjustments for alignment and make certain all setscrews, bolts and nuts are tight. Fit chain around both sprockets and bring the free ends together on one sprocket for connection. The sprocket teeth will locate the chain end links. Install the connecting link, connecting link cover plate and the spring clip or cotter pins. On larger pitch chains or heavy multiple strand, it may be necessary to lock the sprockets for this operation.

CHAIN TENSION

Check chain tension to be certain the slack span has an approximate 2% mid-span movement.

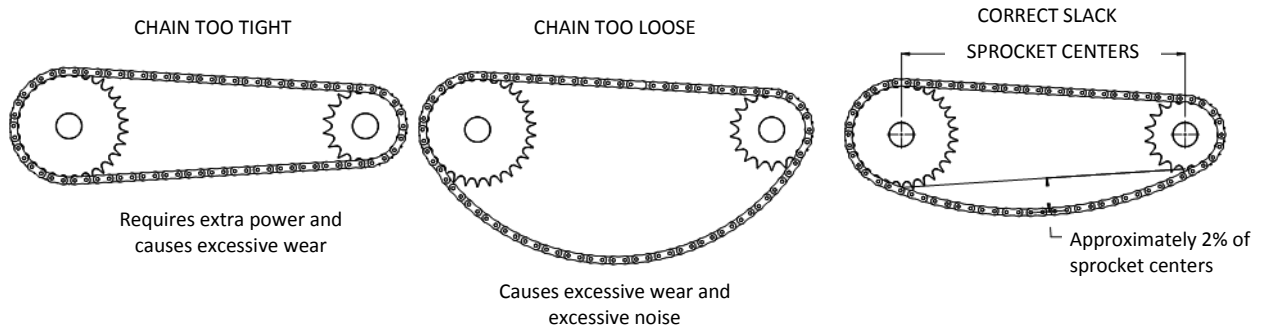

PRE-START-UP OVERVIEW: GEAR REDUCER VENT PLUG

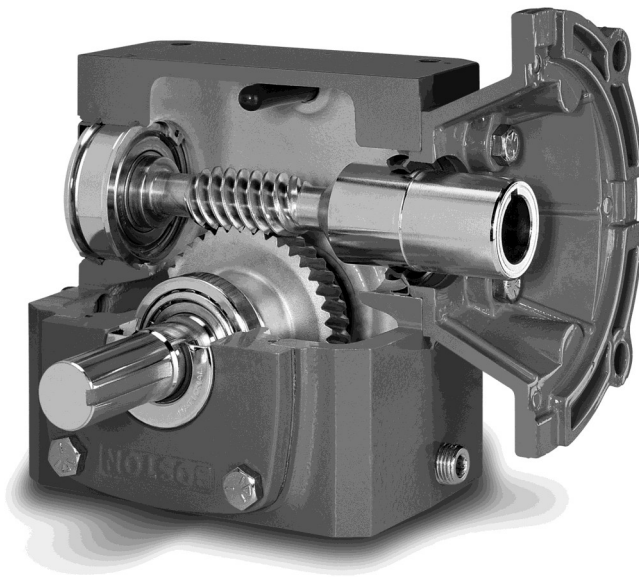

PosiVent®

Omni Metalcraft Corp. standardly supplies the Boston Gear PosiVent® option for all current 700 series styles and configurations. This specially-designed internal pressure equalization system allows the gearbox to operate in all environments without the use of conventional pressure vents. The unique design comes complete with Klubersynth UH1 6-460 lubrication pre-filled for all mounting positions. Unlike competitive versions, this unique single seam design allows for easy installation and extended life. This means longer trouble-free operation with virtually no maintenance.

MAINTENANCE: INSPECTION AND LUBRICATION

CARE AND MAINTENANCE OF CHAIN

Proper maintenance of any chain should include correct lubrication, periodic inspection and proper adjustment for normal wear. Periodic inspection of the chain and sprockets is required to detect any deviation from normal wear before serious damage takes place. The cost of such inspection is repaid many times in extended chain life and in freedom from failure. No general rule can be given for the frequency of inspection. The frequency should be influenced by conditions of operation.

CHAIN LUBRICATION AND ENVIRONMENT

One of the most important factors in getting the best possible performance out of our drive chain is proper lubrication. A well lubricated chain will have an operating life much longer than that of an unlubricated chain. Wear between the pin and bushing causes drive chain to elongate. These parts should, therefore, be well lubricated. The gap between the roller link plate and the pin link plate on the slack side of the chain should be filled with oil. This oil forms a film which minimizes wear on the pin and bushing, thus increasing the chain's service life. It also reduces noise and acts as a coolant when the chain runs at high speeds.

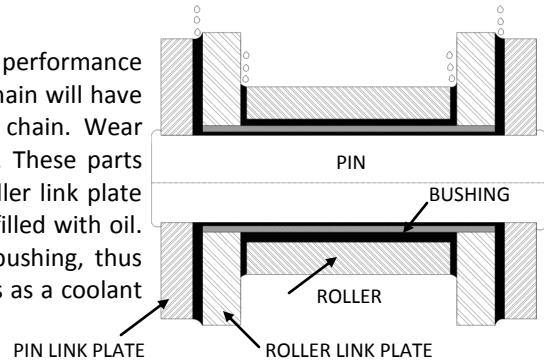

Clean Atmosphere: Chains operating in a relatively clean atmosphere can be lubricated by brush or drip-feed oilers or by applying the lubricant manually with a brush or oil can.

Atmosphere with Lint or Non-Abrasive Dust: Where large volumes of lint or non-abrasive dust are present, a brush or wiper can be used to clean the chain and apply a lubricant. Otherwise the lint or dust will clog the chain joint clearance and prevent penetration of the oil into the joints.

Abrasive Atmosphere: If abrasives come in contact with chain, lubrication becomes more difficult. When lubricants are applied externally, abrasive particles tend to adhere to the chain surfaces and act as a lapping or grinding compound. Under extreme conditions it is sometimes advisable to avoid chain lubrication.

Extreme Conditions: Consult a lubricant manufacturer when chains are required to operate at temperatures outside of those indicated in the chart below or if chains are used in other extreme conditions.

SUGGESTED LUBRICATION

Only high quality oil should be used to lubricate chain. Neither heavy oil nor grease is suitable. The lubricant should have a viscosity to enable it to reach internal surfaces under normal conditions. Lubricants suggested for specific ambient temperatures and chain speed ranges are given in the table below.

CHAIN NUMBER	TEMPERATURE			
	15° - 35° F	35° - 105° F	105° - 120° F	120° - 140° F
ANSI 25 - 50	SAE10W	SAE20	SAE30	SAE40
ANSI 60 - 100	SAE20	SAE30	SAE40	SAE50
ANSI 120 - 240	SAE30	SAE40	SAE50	
4" & 6" PITCH (ENGINEERED CHAIN)	SAE20	SAE30		SAE40

MAINTENANCE: MAINTENANCE SCHEDULES

Note:

Review pages 9 and 10 prior to maintaining any equipment.

If equipment repair or replacement is required during inspections, thoroughly review the manufacturer's specific product information for correct procedure.

DAILY MAINTENANCE

- Inspect all conveyors to ensure that all guarding is securely in place.

WEEKLY MAINTENANCE

- Inspect bearings, gear reducers, motors and chains for excessive noise.

MONTHLY MAINTENANCE

- Inspect oil level in reducer. Fill if necessary.
- Inspect reducer for leaking seals.
- Inspect conveyor for loose bolts.
- Inspect drive chains, jump chains and sprockets for wear, alignment and proper chain tension. For chain lubrication see page 25.

QUARTERLY MAINTENANCE

- Grease all U-joints in curves. Remove rollers in area of U-joint. Then remove finger guard plate over U-joint to gain access to grease fitting.
- Inspect conveyors for worn or broken drive belts. Replace as necessary. If belt shows signs of abrasion, check for hindrance with the belt or foreign object in the roller groove.

SEMI-ANNUAL MAINTENANCE

- Tighten all bearing set screws if not completely tight.

ANNUAL MAINTENANCE

- Change oil in reducers. (If your conveyor is equipped with a Boston 700 Series Reducer, it is filled with oil, sealed and lubed for life thus requiring no oil changes. See manufacturer's information for recommended lubricant at specific temperatures. This information is shipped with every reducer.)

MAINTENANCE: REPORT ON MISCELLANEOUS MAINTENANCE PERFORMANCE

REPORT ON MISCELLANEOUS MAINTENANCE PERFORMANCE

Date _____

Maintenance Performed:

Date _____

Maintenance Performed:

Date _____

Maintenance Performed:

Date _____

Maintenance Performed:

Date _____

Maintenance Performed:

Date _____

Maintenance Performed:

Date _____

Maintenance Performed:

TROUBLESHOOTING AND REPLACEMENT PARTS: TROUBLESHOOTING

PROBLEM	CAUSE	SOLUTION	
Insufficient Drive	Not enough rollers being driven	Drive more rollers, if available	
	Poor bottoms on product	Improve conveyability	
	Overloading product	Remove overload	
	Lubricant on drive shaft	Clean shaft with liquid degreaser	
	Lubricant on belts, rollers and drive pulleys	Clean belts, rollers and pulleys	
	Weak belt (see Weak Belts)	Replace belts	
	Interference	Locate and correct interface	
Weak Belts	Reaction to chemical	Correct cause	
	Excessive temperature	Replace belt	
	Ultraviolet rays (sun)	Replace belt	
Rollers Not Turning or Turning Slowly	Weak belt (see Weak Belts)	Replace belts	
	Bad bearings in rollers	Replace rollers	
	Interference with roller or belt	Remove interference	
	Roller bent	Replace roller	
	Belt rubbing on interference	Correct cause	
	Poor belt joint (replacement belt)	Replace belt	
Broken Belt	Belt rubbing on interference	Correct cause	
	Poor belt joint (replacement belt)	Replace belt	
Belt Out of Groove	Drive shaft location	Move shaft	
	Very dry conditions	Lightly oil groove	
	Groove mislocated	Replace roller	
Vibration in Drive Shaft	Misalignment in bearings	Loosen bearing and readjust shaft	
	Bent shaft	Replace shaft	
	Misalignment in couplings	Realign coupling	
	Universal out of phase	Key one end of center shaft in alignment with opposite key	
		Equalize angles	
Pulsation After Curve or Merge	Angle of universal not equal	Readjust coupling	
Drive Shaft Bearing Noisy	Misaligned drive shaft	Loosen bearing	
	Bad bearings	Replace bearing	
Reducer or Motor Noisy	Insufficient lubricant	Add recommended oil	
	Output shaft or chain rubbing chain guard	Adjust guard	
	Bent fan housing, worn brushes and worn bearing	Repair or replace part	
Broken Coupler Chain	Improper chain installation	Replace chain	
	Misalignment	Realign shafts	
Reducer Oil Leakage	Over filling	Drain lubricant to proper level	
	Vent in wrong location	Place vent in uppermost position	
		Extend vent with pipe nipple	
		Tighten all bolts and fittings	
Worn Seal	Replace seal		
Sprocket Wear	Loose chain	Tighten chain	
	Misalignment	Check alignment with straight edge along side of chain	
	Running dry	Lubricate	

TROUBLESHOOTING AND REPLACEMENT PARTS: TROUBLESHOOTING

PROBLEM	CAUSE	SOLUTION
Start Overloads Kicking Out	Wrong size overloads	Use proper size overloads
	Motor too small	Replace motor with proper size
	Defective motor	Replace motor
Non-Symmetrical Wear on Sprockets or Rollers	Shafts out of parallel or not in same place	Realign sprockets
Wear on Inside of Roller Plates or Side of Sprocket Teeth	Sprockets offset on shaft (misaligned) or out of parallel	Realign sprockets
Wear on Tips of Sprocket Teeth	Chain elongated excessively	Replace chain
	Loose chain	Tighten chain
Broken Chain Parts or Sprocket Teeth	Drive overloaded	Avoid overloading
	Excessive slack causing chain to jump teeth	Periodically adjust center distance
	Foreign object	Remove object and prevent entry
	Inadequate lubrication	Maintain proper lubrication intervals
	Corrosion	Remove source of corrosion or use non-corrosive chain
Excessive Chain Noise	Chain contacting fixed objects	Remove objects
	Inadequate lubrication	Maintain proper lubrication intervals
	Broken or missing rollers	Repair or replace chain
	Shaft and sprocket misalignment	Realign
	Chain jumping sprocket teeth	Adjust center distance between sprockets, tightening the chain

PARTS LISTS: LINESHAFT STRAIGHT

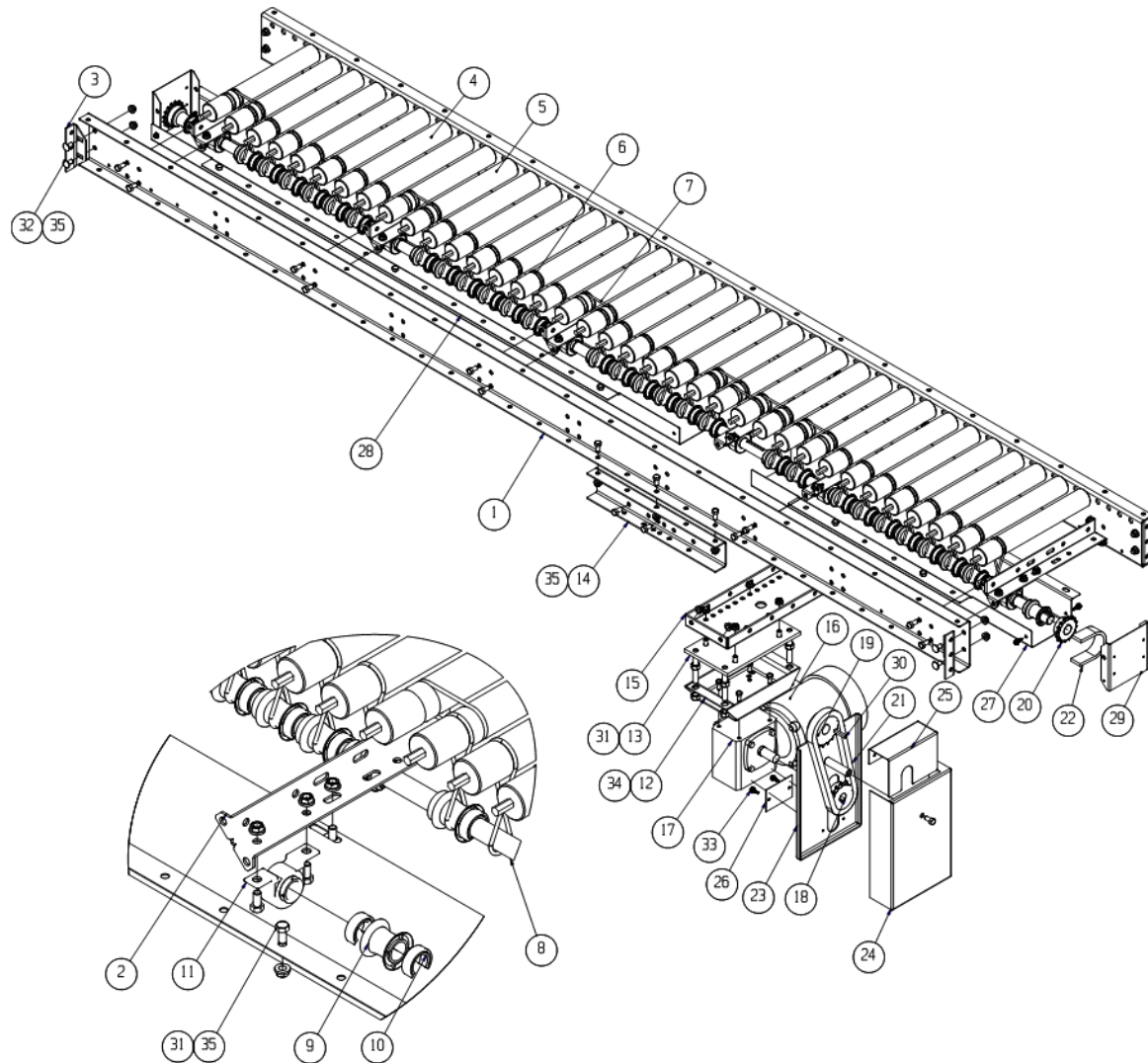

DETAIL	DESCRIPTION	DETAIL	DESCRIPTION
1	SIDEFRAAME	19	DRIVEN SPROCKET
2	BOLT-IN SPREADER	20	COUPLER SPROCKET
3	END COUPLER	21	DRIVE CHAIN
4	GROOVED ROLLER: 1 GROOVE	22	COUPLING CHAIN
5	GROOVED ROLLER: 2 GROOVES	23	CHAIN GUARD: BACK
6	URETHANE DRIVE BELT	24	CHAIN GUARD: FRONT
7	URETHANE SLAVE BELT	25	FINGER GUARD
8	DRIVE SHAFT	26	SLOT GUARD
9	SPOOL	27	SPOOL GUARD: SHORT SECTION
10	SPOOL SPACER	28	SPOOL GUARD: LONG SECTION
11	PEER PILLOW BLOCK BEARING	29	SPOOL GUARD END CAP
12	REDUCER CARRIAGE PLATE	30	KEYSTOCK
13	VERTICAL TAKE-UP PLATE	31	HEX HEAD CAP SCREW
14	DRIVE SUPPORT CHANNEL	32	CARRIAGE BOLT
15	CHANNEL SPREADER	33	SELF TAPPING SCREW
16	MOTOR	34	HEX NUT
17	REDUCER	35	WHIZ NUT
18	DRIVE SPROCKET		

PARTS LISTS: LINESHAFT CURVE

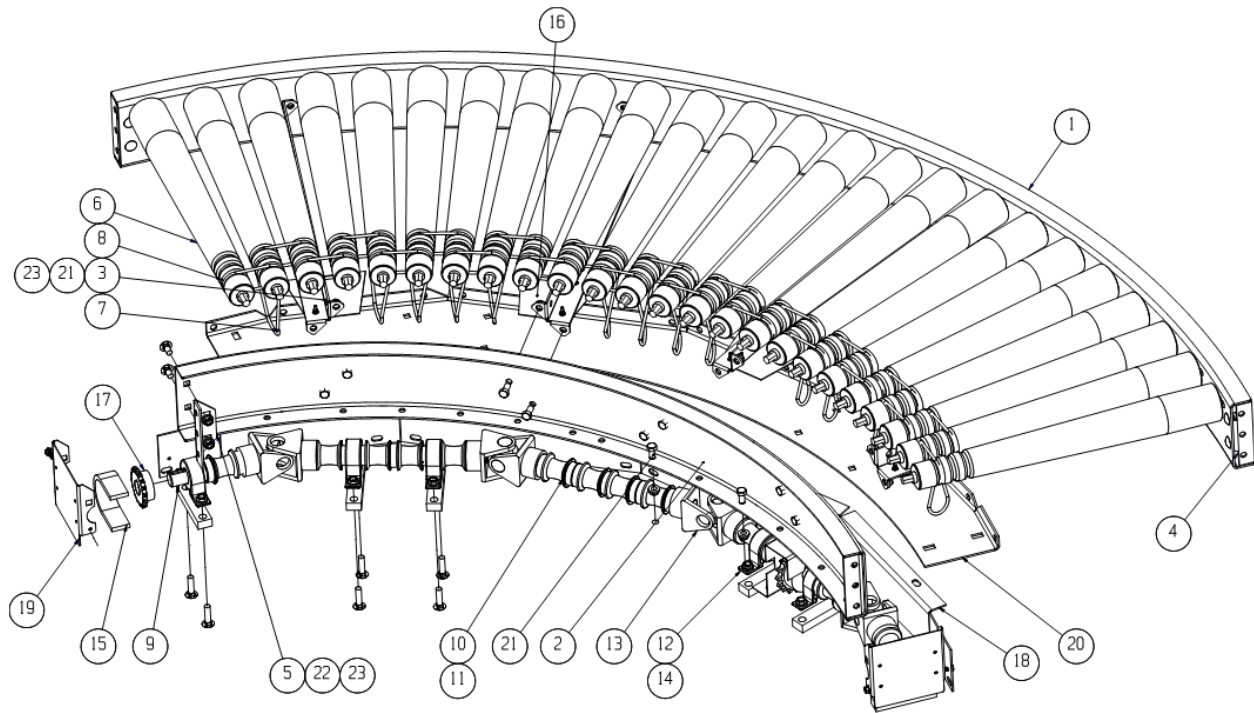

DETAIL	DESCRIPTION
1	OUTSIDE RAIL
2	INSIDE RAIL
3	BOLT-IN SPREADER
4	END COUPLER: OUTSIDE RAIL
5	END COUPLER: INSIDE RAIL
6	GROOVED TAPERED ROLLER: 3 GROOVES
7	URETHANE DRIVE BELT
8	URETHANE SLAVE BELT
9	DRIVESHAFT
10	SPOOL
11	SPOOL SPACER
12	PILLOW BLOCK BEARING
13	U-JOINT
14	BEARING MOUNTING BLOCK
15	CHAIN COUPLING
16	U-JOINT FINGER GUARD
17	COUPLER SPROCKET
18	SPOOL GUARD
19	SPOOL GUARD END CAP
20	FRONT GUARD
21	HEX HEAD CAP SCREW
22	CARRIAGE BOLT
23	WHIZ NUT

PARTS LISTS: LINESHAFT CURVE WITH TANGENT (30° shown)

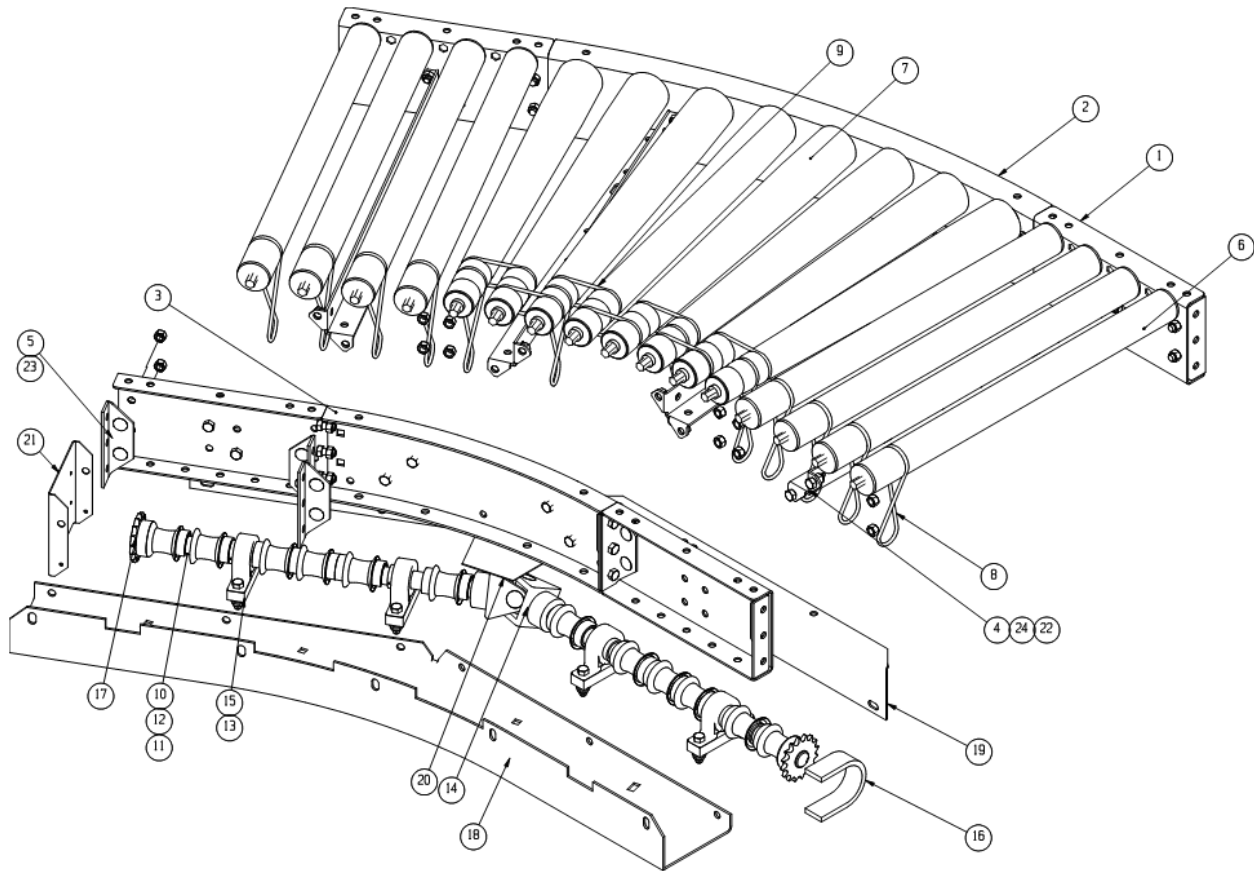

DETAIL	DESCRIPTION
1	TANGENT SIDEFRAME
2	OUTSIDE RAIL
3	INSIDE RAIL
4	BOLT-IN SPREADER
5	END COUPLER
6	GROOVED ROLLER: 1 GROOVE
7	GROOVED TAPERED ROLLER: 3 GROOVES
8	URETHANE DRIVE BELT
9	URETHANE SLAVE BELT
10	DRIVE SHAFT
11	SPOOL
12	SPOOL SPACER
13	PEER PILLOW BLOCK BEARING
14	U-JOINT
15	BEARING MOUNTING BLOCK
16	COUPLING CHAIN
17	COUPLER SPROCKET
18	SPOOL GUARD: FRONT
19	SPOOL GUARD: BACK
20	SPOOL GUARD: TOP
21	SPOOL GUARD END CAP
22	HEX HEAD CAP SCREW
23	CARRIAGE BOLT
24	HEX NUT

PARTS LISTS: LINESHAFT SPUR

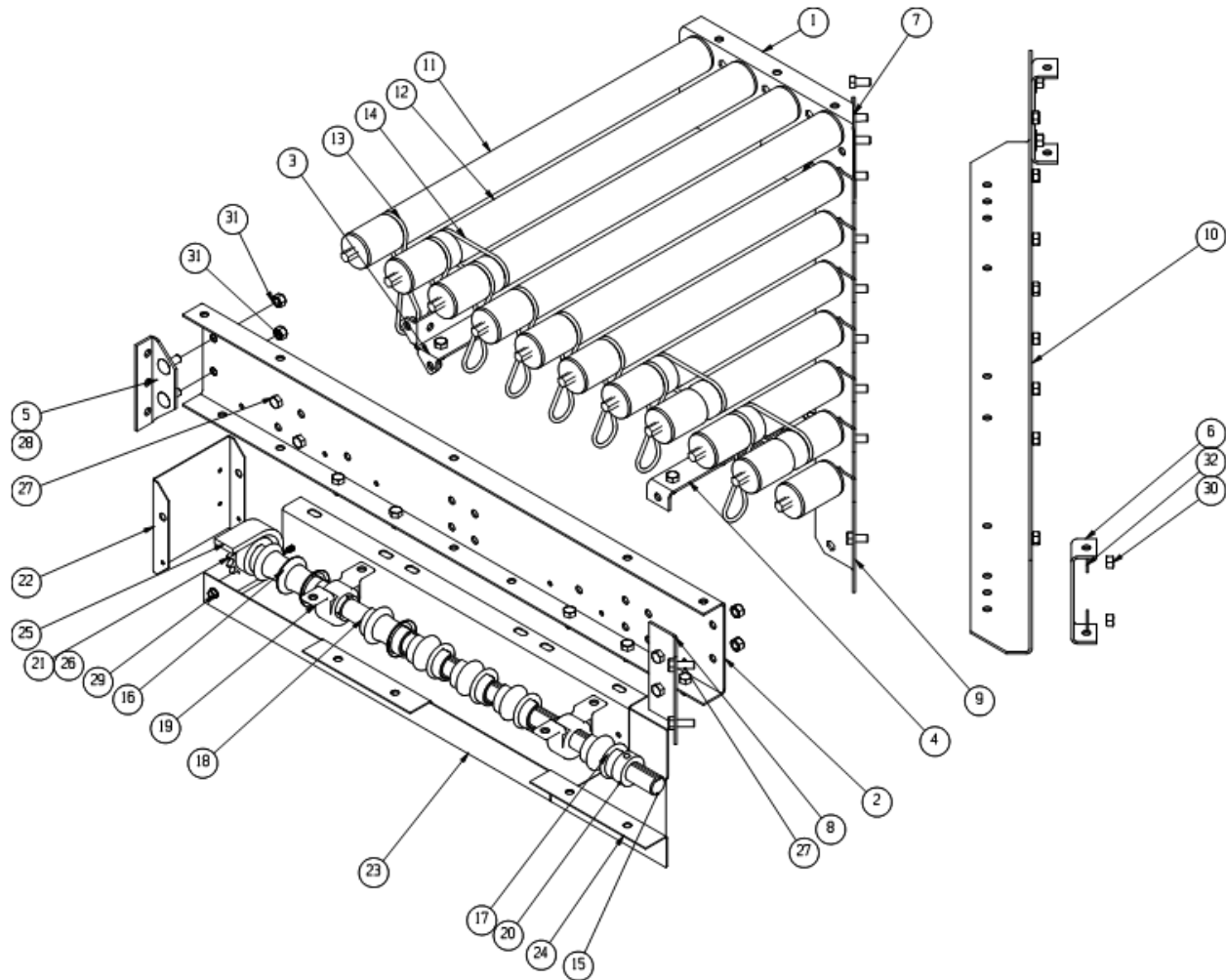

DETAIL	DESCRIPTION	DETAIL	DESCRIPTION
1	SHORT RAIL	17	KEYED SPOOL
2	LONG RAIL	18	SPOOL SPACER
3	BOLT-IN SPREADER	19	PEER PILLOW BLOCK BEARING
4	SPUR SPREADER	20	SHAFT COLLAR
5	END COUPLER	21	COUPLER SPROCKET
6	MOUNTING BRACKET	22	SPOOL GUARD END CAP
7	STABILIZING BRACKET: SHORT RAIL	23	SPOOL GUARD: LONG
8	STABILIZING BRACKET: LONG RAIL	24	SPOOL GUARD: SHORT
9	HEX SUPPORT	25	CHAIN COUPLING
10	SHELF BRACKET	26	KEYSTOCK
11	GROOVED ROLLER: 1 GROOVE	27	HEX HEAD CAP SCREW
12	GROOVED ROLLER: 2 GROOVES	28	CARRIAGE BOLT
13	URETHANE DRIVE BELT	29	SELF TAPPING SCREW
14	URETHANE SLAVE BELT	30	HEX NUT
15	DRIVE SHAFT	31	WHIZ NUT
16	SPOOL	32	FLAT WASHER

PARTS LISTS: LINESHAFT SPUR

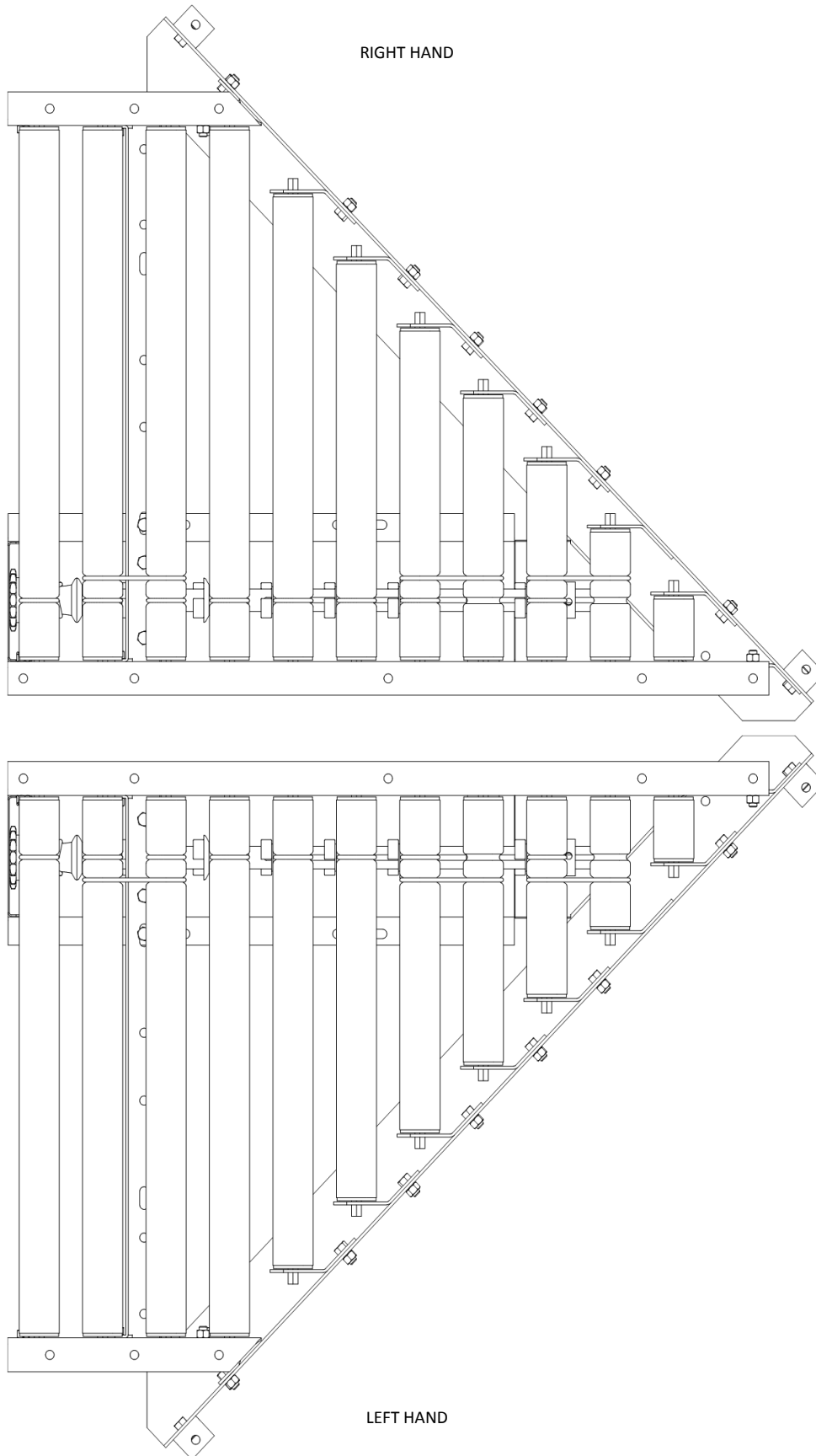

ABBREVIATED WARRANTY

Omni Metalcraft Corp. warrants that the Equipment will be free of defects in workmanship and material (if properly installed, operated and maintained) for a period of one year or 2080 hours of use, whichever is sooner, from date of shipment to Customer, subject to the limitations hereunder set forth. If within the one year warranty period, Omni receives from the Customer written notice of any alleged defects in the Equipment and if the Equipment is not found to be in conformity with this warranty (the Customer having provided Omni a reasonable opportunity to perform any appropriate tests thereon) Omni will, at its option, either repair the Equipment or supply a replacement therefore.

*The above stated information is in reference to a section of Omni Metalcraft's full Terms and Conditions of sale. This information does not constitute an agreement, but simply reference information. To obtain a full copy of Omni Metalcraft's Terms and Conditions of Sale, please contact your Sales Representative.

Omni Metalcraft Corp.

P.O. Box 352 ■ Alpena, Michigan 49707
Phone 989.358.7000
Fax 989.358.7020
info@omni.com